

# smartzone<sup>™</sup> UPS

## **Installation Manual**

1-20 kVA Uninterruptible Power Supply,

1-20 kVA External Battery Pack,

Maintenance Bypass Switch,

Battery Cartridges,

## Contents

Section 1 – Overview .....	4
Section 2 – Handling (Safety) .....	5
Important Safety Warnings .....	5
Overview .....	5
Handling Instructions .....	5
Preparation .....	5
Installation .....	5
Operation .....	6
Maintenance, service, and faults .....	7
Section 3 – UPS, EBP and MBS Mounting .....	8
Racks .....	8
Four-Post Racks .....	8
<b>2U UPS Units (U01N11V, U01S11V, U01N12V, U01S12V, U01N13V, U01S13V, U02N11V, U02S11V, U02N12V, U02S12V, U03N11V, U03S11V, U03N12V, U03S12V) .....</b>	<b>8</b>
<b>2U EBP Units (UVP024, UVP036, UVP048, UVP072) .....</b>	<b>13</b>
<b>3U UPS Units (U05N11V, U05S11V, U06N11V, U06S11V, U06N12V, U06S12V, U10N11V, U10S11V, U10N12V, U10S12V, U10N32V, U10S32V, U15N32V, U15S32V, U20N32V, U20S32V) .....</b>	<b>18</b>
<b>3U EBP Unit (UVP240) .....</b>	<b>22</b>
<b>3U MBS Unit (UMB20K) .....</b>	<b>28</b>
<b>4U EBP Unit (UVP480) .....</b>	<b>32</b>
Two-Post Racks .....	36
Tower .....	36
2U Units (U01N11V, U01S11V, U01N12V, U01S12V, U01N13V, U01S13V,	

U02N11V, U02S11V, U02N12V, U02S12V, U03N11V, U03S11V, U03N12V, U03S12V, UVP024, UVP036, UVP048, UVP072) ..... 37

3U Units (U05N11V, U05S11V, U06N11V, U06S11V, U06N12V, U06S12V, U10N11V, U10S11V, U10N12V, U10S12V, UVP240) ..... 39

3-Phase Units (U10N32V, U10S32V, U15N32V, U15S32V, U20N32V, U20S32V, UVP480, UMB20K) ..... 40

Section 4 – Electrical Connections ..... 41

1-10kVA Single Phase UPS and Associated EBP (U01N11V, U01S11V, U01N12V, U01S12V, U01N13V, U01S13V, U02N11V, U02S11V, U02N12V, U02S12V, U03N11V, U03S11V, U03N12V, U03S12V, U05N11V, U05S11V, U06N11V, U06S11V, U06N12V, U06S12V, U10N11V, U10S11V, U10N12V, U10S12V, UVP024, UVP036, UVP048, UVP072, UVP240) ..... 41

10-20kVA 3-Phase UPS and Associated EBP (U10N32V, U10S32V, U15N32V, U15S32V, U20N32V, U20S32V, UVP480) ..... 43

    Single Mode System Configuration with 3-Phase or Single-Phase Output ..... 43

    Parallel Mode System Configuration with 3-Phase or Single-Phase Output ..... 48

    Optional MBS for 3-Phase UPS ..... 51

Section 5 – Replacing Battery Cartridges ..... 52

Internal Battery Cartridges in the 1-3kVA UPS Units (UVC024, UVC036, UVC048, UVC072) ..... 52

EBP Battery Cartridge Sets for the 1-3kVA UPS Systems (UVD024, UVD036, UVD048, UVD072) ..... 54

EBP Battery Cartridge Sets for the 5-10kVA UPS Systems (UVD240) ..... 56

EBP Battery Cartridge Sets for the 10-20kVA 3-Phase UPS Systems (UVD480) ..... 58

Appendix A: What’s Included: 1-3kVA NA UPS (U01N11V, U01S11V, U01N13V, U01S13V, U02N11V, U02S11V, U03N11V, U03S11V,) ..... 60

Appendix B: What’s Included: 1-3kVA EU UPS (U01N12V, U01S12V, U02N12V, U02S12V, U03N12V, U03S12V) ..... 61

Appendix C: What’s Included: 1-3kVA EBP (UVP024, UVP036, UVP048, UVP072) .... 62

Appendix D: What’s Included: 5-10kVA UPS (U05N11V, U05S11V, U06N11V, U06S11V, U06N12V, U06S12V, U10N11V, U10S11V, U10N12V, U10S12V) ..... 63

Appendix E: What’s Included: 10-20kVA UPS (U10N32V, U10S32V, U15N32V, U15S32V, U20N32V, U20S32V) ..... 64

---

Appendix F: What's Included: 5-10kVA EBP (UVP240) .....	65
Appendix G: What's Included: 10-20kVA EBP (UVP480) .....	66
Appendix H: What's Included: Maintenance Bypass Switch (UMB20K) .....	67

## Section 1 – Overview

This Manual provides the instructions for installing the Uninterruptable Power Supply Units, the External Battery Pack Units, the Maintenance Bypass Switch Unit, and the UPS/EBP Battery Cartridges.

All units require mounting support when mounted in a rack. A rail mounting kit and a tower mounting kit are provided with most units. The rail mounting kit is used for the preferred mounting, in a four-post rack. The tower mounting kit is used for mounting on the floor or desk in a vertical orientation.

Refer to the appropriate Appendix in this manual for a detailed list of the components included with the product.

The following three sections provide the information on handling, installing, and wiring the chassis in this manual. There are many common installation steps between the various unit models. Subsections are provided for unique installation step that must be completed on specific models.

## Section 2 – Handling (Safety)

### Important Safety Warnings

Important safety instructions – Save these instructions







#### Overview

Please comply with all warnings and operating instructions. Save this manual for future reference. Carefully read and follow these instructions before installing the unit. Do not operate this unit before reading through all safety information and operating instructions carefully.

Dangerous voltages and high temperatures exist inside the UPS. During the installation, operation, and maintenance of these units, please abide by the local safety rules and relative laws. Failure to do so may result in personnel injury or equipment damage. Safety instructions in this manual act as a supplementary for the local safety rules. No liability is assumed for not following the safety rules.

#### Handling Instructions

Before moving the UPS, be sure to use the original packaging materials to prevent or reduce the possibility of personal injury or damage to the product.

	< 18kg		18-32kg		32-55kg		> 55kg		
	< 40lb		40-70lb		70-120lb		> 120lb		

#### Preparation

1. Condensation must be taken if the UPS system is moved directly from a cold to warm environment. The UPS system must be free of any moisture before being installed. Please allow at least two hours for the UPS system to acclimate to the environment.
2. Do not install the UPS system near water or in humid environments.
3. Do not install the UPS system where it would be exposed to direct sunlight or near heat sources.
4. Do not block ventilation holes in the UPS housing.
5. It is recommended to mount the UPS and EBP unit near the bottom of the rack due to the physical weight of these units.

#### Installation

6. Do not connect appliances or devices which would overload the UPS system to the UPS output.

7. Route cables to eliminate tripping hazards.
8. Do not connect domestic appliances such as hair dryers to UPS output.
9. Connect the UPS system only to an earth grounded outlet that is easily accessible and close to the UPS system.
10. Use only UL, VDE, CE certified power cables to connect the UPS system to the building wiring source (Mains).
11. Use only UL, VDE, CE certified power cables to connect the loads to the UPS system.
12. When installing the equipment, ensure that the sum of the leakage current of the UPS and the connected devices does not exceed 3.5mA.
13. This product should be installed in an area with an altitude of less than 1000m. In places over 1000m, the unit must be derate 1% for every 100 meters above 1000m. This is an example of power derating according to altitude:

Altitude (m)	1000	2000	2500	3000	3500	4000	4500	5000
Load coefficient	100%	90%	85%	80%	75%	70%	65%	60%

14. The UPS cooling is depending on fans, so it should be kept in good air ventilation area. There are many ventilation holes on the front and rear, so they should not be blocked by any exotic obstacles.
15. Batteries should be mounted in an environment where the temperature is within the required specs. Temperature is a major factor in determining battery life and capacity. In a normal installation, the battery temperature is maintained between 15°C and 25°C. Keep batteries away from heat sources or main air ventilation area, etc.
16. Units with internal battery cartridges and battery cartridges must be stored in an environment to protect against excessive humidity and heat source.
  - Typical battery performance is based on an operating temperature between 20°C and 25°C. Operating the battery cartridges above this range will reduce the battery life, while operating below this range will reduce the battery capacity.
  - An unused battery cartridge must be fully recharged every 6 months.

## Operation

17. Do not disconnect the input (Mains) cable on the UPS system or the building wiring source, thus removing protective earth of the UPS system and of all connected loads, during operation.
18. The UPS system features its own, internal power source (batteries). The UPS output may be electrically live even if the UPS system input is not connected to the building source.
19. To fully disconnect the UPS system, first press the OFF/Enter button then disconnect the input source (Mains).
20. Prevent fluids or other foreign objects from entering the UPS system.

## Maintenance, service, and faults

21. The UPS system operates with hazardous voltages. Repairs should be performed by qualified maintenance personnel only.
22. Caution – There is risk of electric shock even after the unit is disconnected from the input source (Mains), components inside the UPS system are still connected to the battery and electrically live and dangerous.
23. Before performing any service and/or maintenance, disconnect the battery cartridge(s) and verify that no hazardous voltage is present on the terminals of the high voltage components such as BUS-capacitors.
24. It is recommended that personal with adequate knowledge of batteries that follow the required precautionary measures should replace the battery cartridge(s) or supervise the replacement of the battery cartridge(s).
25. Caution – there is risk of electric shock. The battery circuit is not isolated from the input voltage. Hazardous voltages may exist between the battery terminals and the ground on the UPS. Before touching, please verify that no voltage is present.
26. Batteries may cause electric shock and have a high short-circuit current. Take the precautionary measures specified below and any other measures necessary when working with the battery cartridges:
  - Remove jewelry and any other metal objects.
  - Use only tools with insulated grips and handles.
  - Avoid touching or shorting battery cartridge terminals.
27. When changing battery cartridge(s), only replace with the same battery cartridge part number as specified for that UPS.
28. Do not attempt to dispose of battery cartridges by burning them. This could cause the batteries to explode.
29. Do not open or destroy batteries. Escaping electrolytes can cause injury to the skin and eyes and may be toxic.
30. Must replace any fuses only with the same type and amperage to avoid fire hazards.
31. Do not disassemble the UPS system.



## Section 3 – UPS, EBP and MBS Mounting

The UPS, EBP and the MBS have different mounting options. Refer to the following section that matches the desired mounting technique desired.

### Racks

Four-post rack mounting is the recommended preferred mounting technique for all UPS, EBP and MBS units. The mounting hardware for this technique is provided with most units. The units may also be mounted in a two-post rack, this will require additional mounting hardware that is specified in the below section. (Note: It is recommended to mount the UPS and EBP unit near the bottom of the rack due to the physical weight of these units). The third mounting option is tower mounting. This is not a preferred mounting technique, but tower mounting stands are provided with most units. The 3-Phase UPS and EBP unit should not use this mounting technique due to physical configuration and physical weight of the unit.

### Four-Post Racks

The UPS, EBP and MBS units comes with all the hardware required for installation in a standard EIA or JIS seismic rated four-post rack with square or M5 threaded mounting holes. The rail assemblies adjust to mount in 19" racks with a distance from front to rear from 460~1000 mm (18 to 39 inches) deep.

**CAUTION**



- *The unit is heavy. Removing the unit from its carton requires a minimum of two people.*
- *If installing optional EBP(s), make sure to install the EBP(s) directly below the UPS so that all wiring between the units can use the wiring provided with the units.*

**NOTE** *Mounting rails are required for each individual unit.*

*2U UPS Units (U01N11V, U01S11V, U01N12V, U01S12V, U01N13V, U01S13V, U02N11V, U02S11V, U02N12V, U02S12V, U03N11V, U03S11V, U03N12V, U03S12V)*

1. Install the rail kit:
2. Install the front side of the rail kit with 3x Phillips Pan Head M5 screws (see Figure 1) on each rail. Do not tighten the screws.

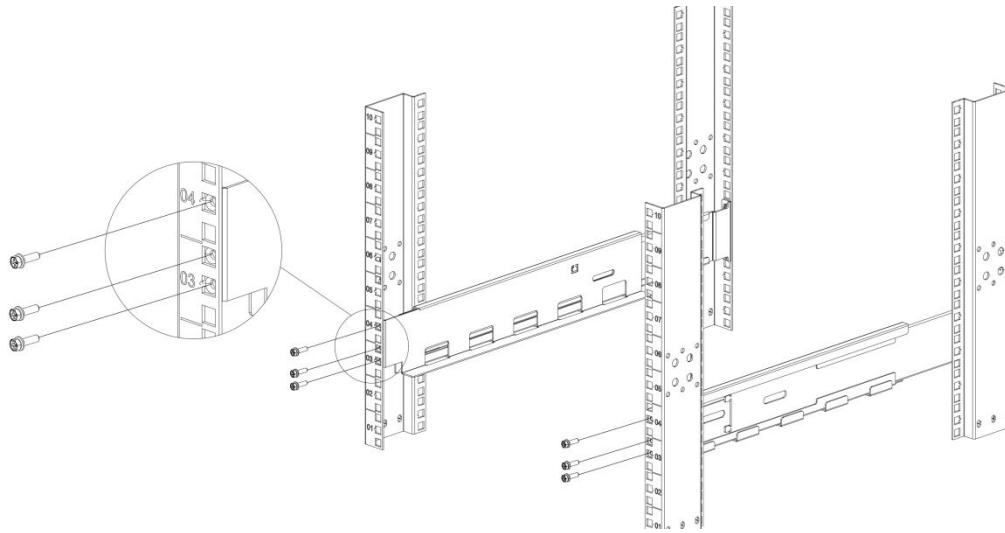

**Figure 1: Install the Front Side of Rails**

3. Adjust the rail size according to the depth of the rack
4. Assemble the rear side of the rail kit with 3x Phillips Pan Head M5 screws (see Figure 2) on each rail.

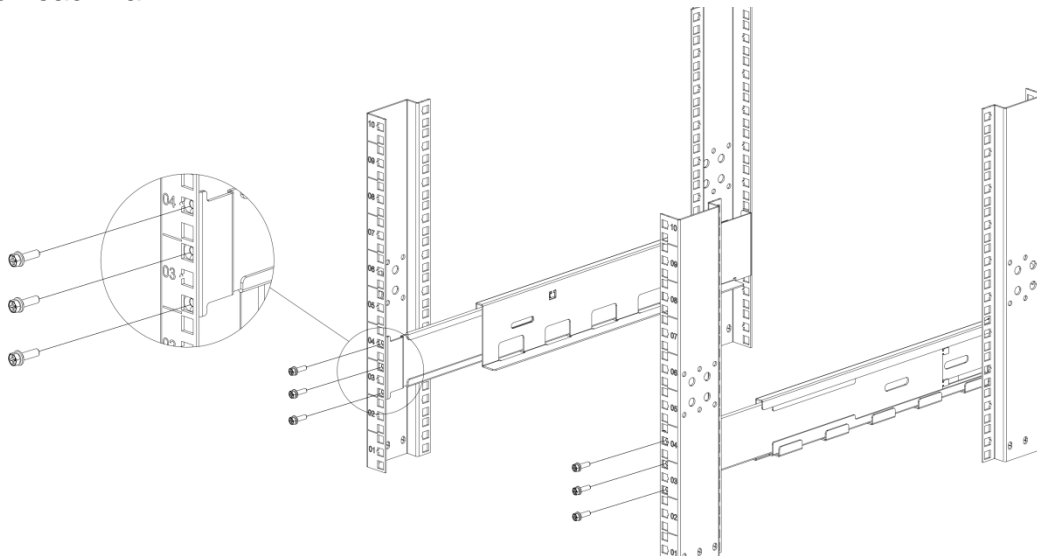

**Figure 2: Install the Rear Side of Rails**

5. Tighten all 12x screws to secure the rail kit to the rack.
6. Install the 4x cage nuts in the rack front equipment rail, with square holes. One in each of the first locations below the bottom rail kit screw and one in each of the first locations above the top rail kit screw (see Figure 3).

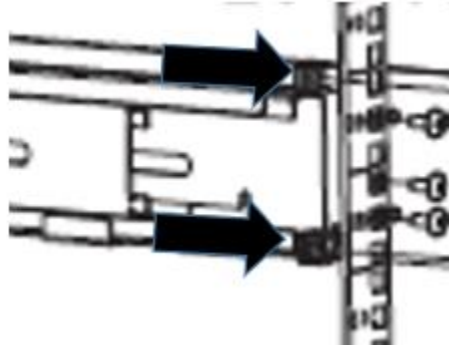

**Figure 3: Install Cage Nuts in the Front Equipment Rail with Square Holes**

7. Remove the faceplate:
8. Press both sides of UPS faceplate until the latches release (see Figure 4).

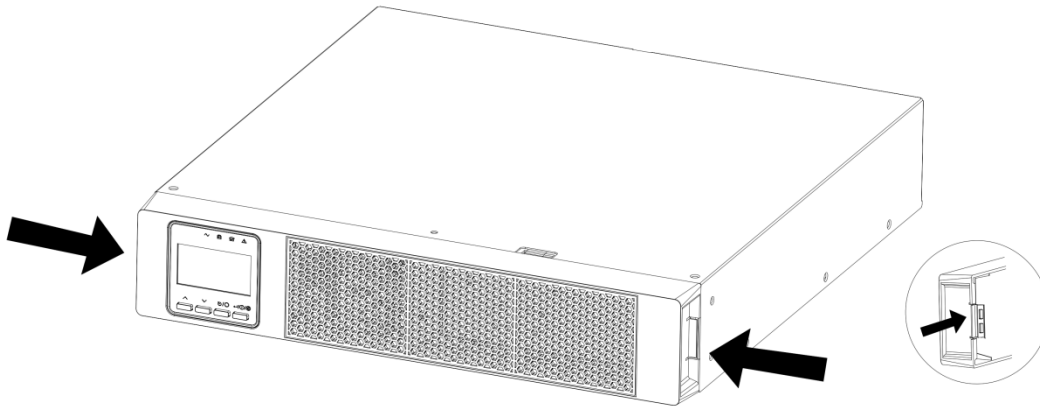

**Figure 4: Press the Latches to Remove Faceplate**

- b) Remove the faceplate (see Figure 5).

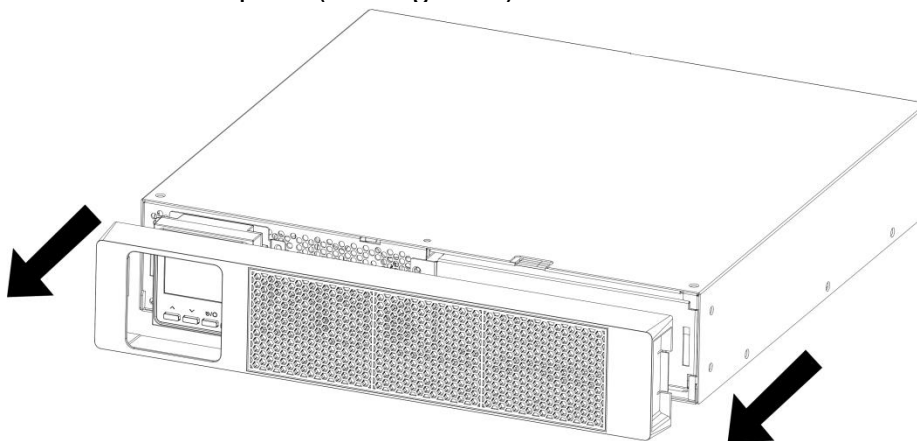

**Figure 5: Remove the Faceplate**

9. Connect the internal battery cartridge:
10. Connect the internal battery cartridge connector (see Figure 6). Press the connector tightly together to ensure a proper connection.

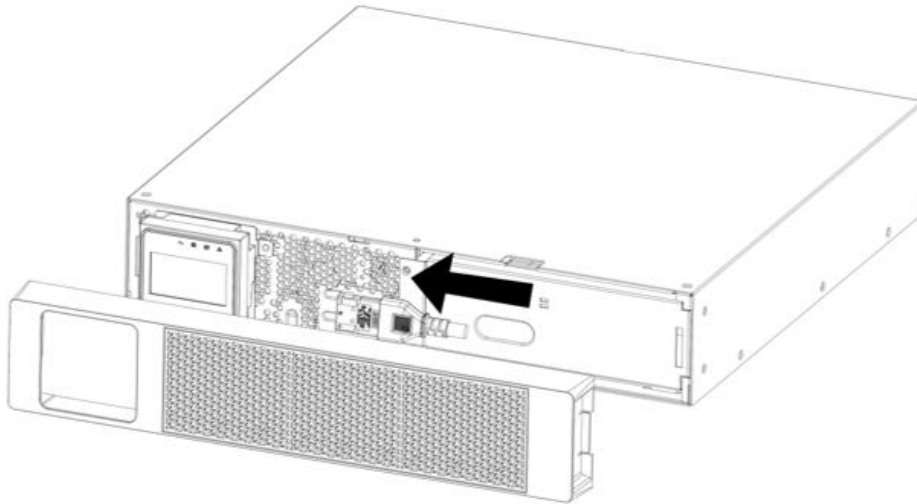

**Figure 6: Connect the Internal Battery Cartridge Connector**

11. Reinstall the faceplate on the UPS, by aligning the front panel display through the hole in the faceplate and snapping the faceplate onto the front of the UPS. Should have a positive snap of the latches on the faceplate.

**CAUTION**



*A small amount of arcing may occur when connecting the internal battery cartridge. This is normal and will not harm personnel. Connect the cables quickly and firmly.*

12. Install the mounting brackets:
13. Remove the 2x Phillips Flat Head M4x8 screws from the front of each side the UPS and retain.
14. Align the mounting brackets with the screw holes on each side of the UPS and secure with the previously removed Phillips Flat Head M4x8 screws (see Figure 7).

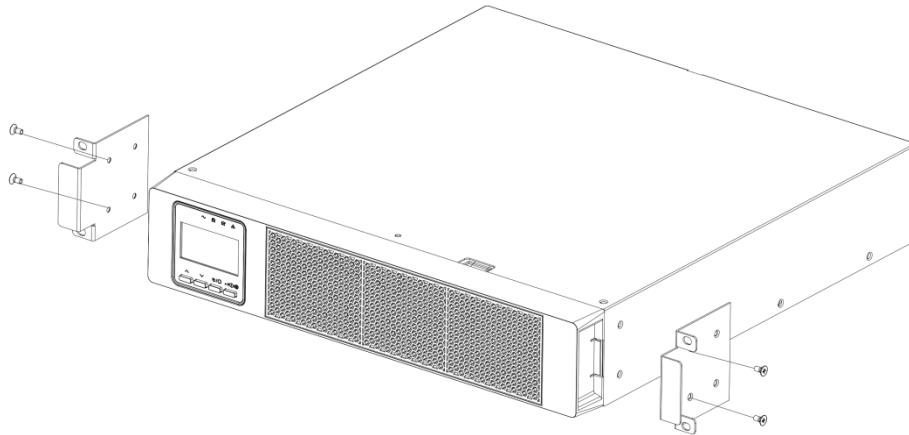

**Figure 7: Install the Mounting Bracket**

15. After installing the mounting brackets onto the UPS, slide the UPS into the rack on the rail kit (see Figure 8).

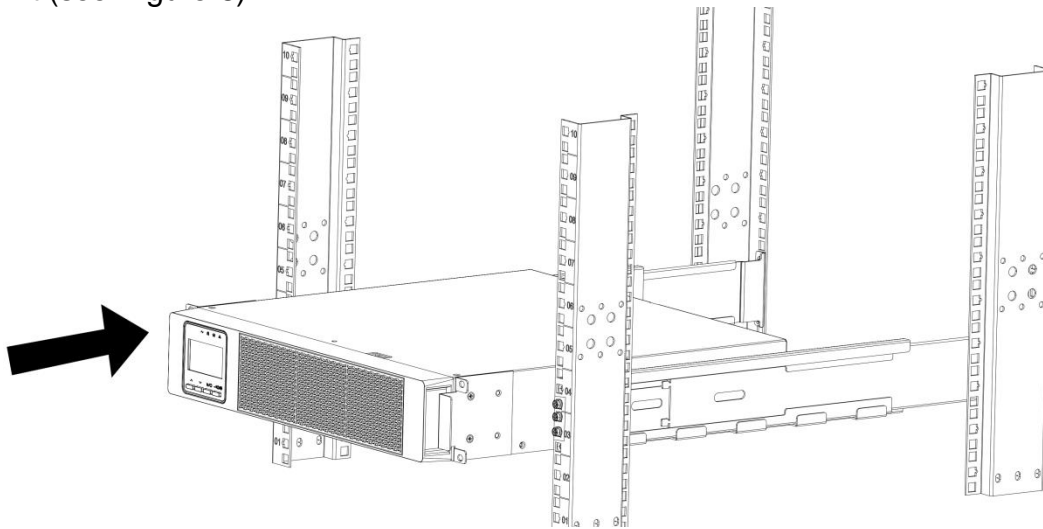

**Figure 8: Slide UPS into the Rack**

16. Align the mounting brackets with the screw holes on the rack and secure the UPS with the supplied 4x Phillips Hex Head M5 screws (see Figure 9).

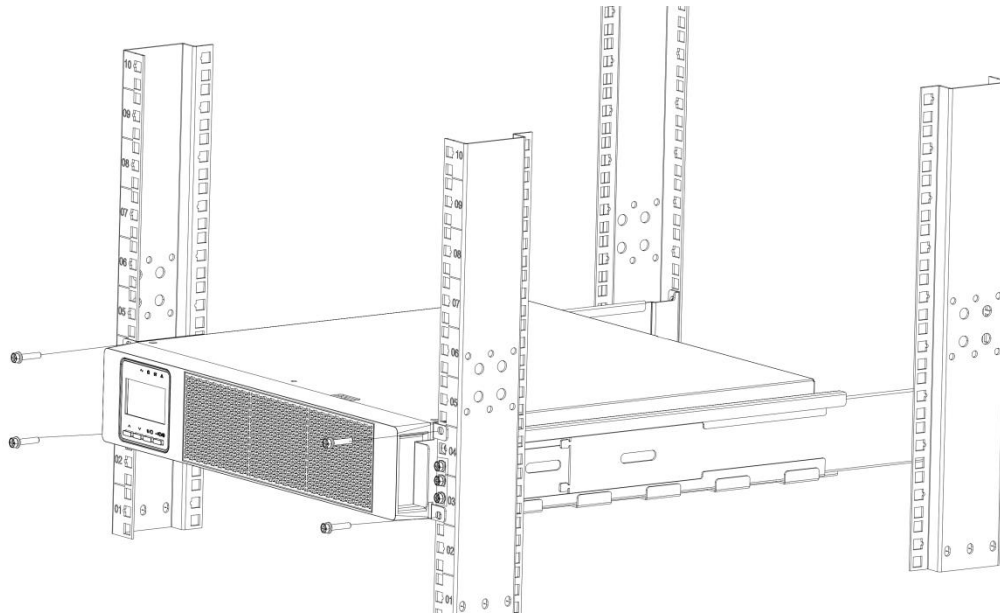
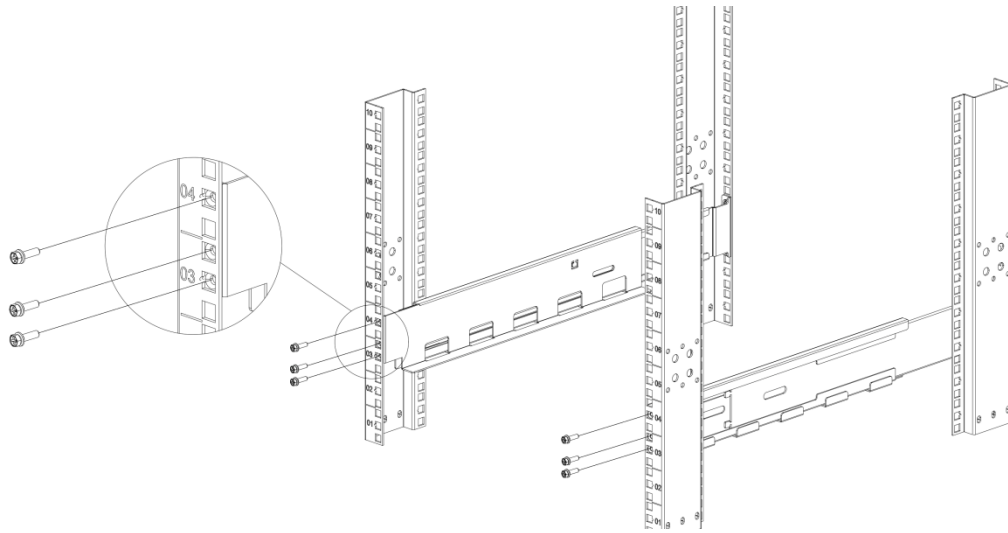

**Figure 9: Secure the Mounting Brackets to the Rack**

*2U EBP Units (UVP024, UVP036, UVP048, UVP072)*

It is recommended to install the first EBP directly under the UPS. It is recommended to install all subsequent EBPs directly under the previous EBP.

1. Install the rail kit:
2. Install the front side of the rail kit with 3x Phillips Pan Head M5 screws (see Figure 10) on each rail. Do not tighten the screws.



**Figure 10: Install the Front Side of Rails**

3. Adjust the rail size according to the depth of the rack
4. Assemble the rear side of the rail kit with 3x Phillips Pan Head M5 screws (see Figure 11) on each rail.

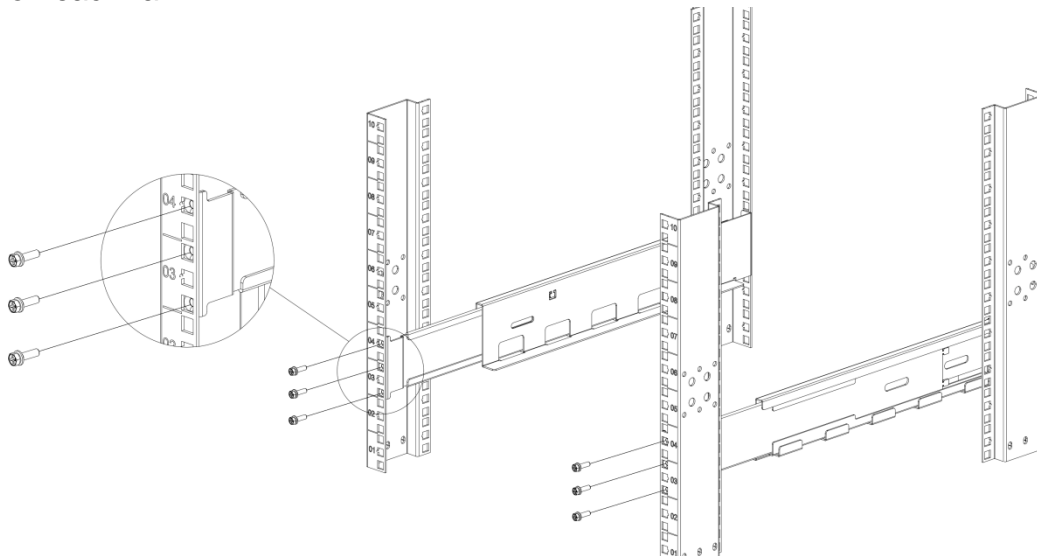

**Figure 11: Install the Rear Side of Rails**

5. Tighten all 12x screws to secure the rail kit to the rack.
6. Install the 4x cage nuts in the rack front equipment rail, with square holes. One in each of the first locations below the bottom rail kit screw and one in each of the first locations above the top rail kit screw (see Figure 12).

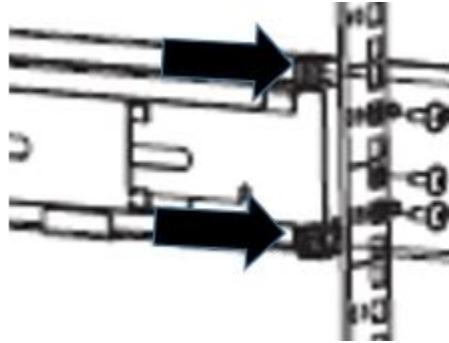

**Figure 12: Install Cage Nuts in the Front Equipment Rail with Square Holes**

7. Remove the faceplate:
8. Press both sides of EBP faceplate until the latches release and remove (see Figure 13).

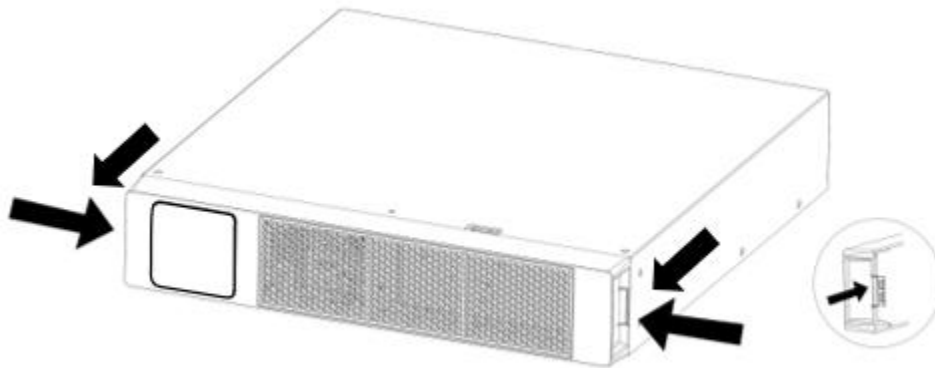

**Figure 13: Press the Latches and Remove Faceplate**

9. Loosen the outer screws on the battery covers, move the battery cover to the center, then pull the outside out (see Figure 14).



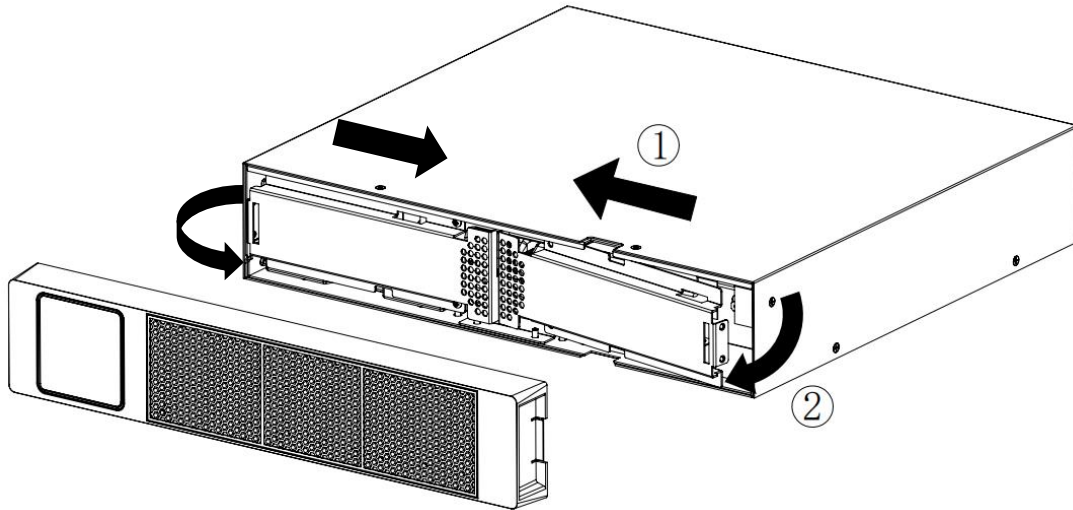

**Figure 14: Remove the Faceplate**

10. Connect the internal battery cartridges:
11. Pull both battery cartridge connectors through the middle hole in the chassis, connect a battery cartridge to each connector (see Figure 15). Press the connector tightly together to ensure a proper connection. Connect the other battery cartridge in the EBP. Both internal battery cartridges should be connected. Press each connector tightly together to ensure a proper connection.

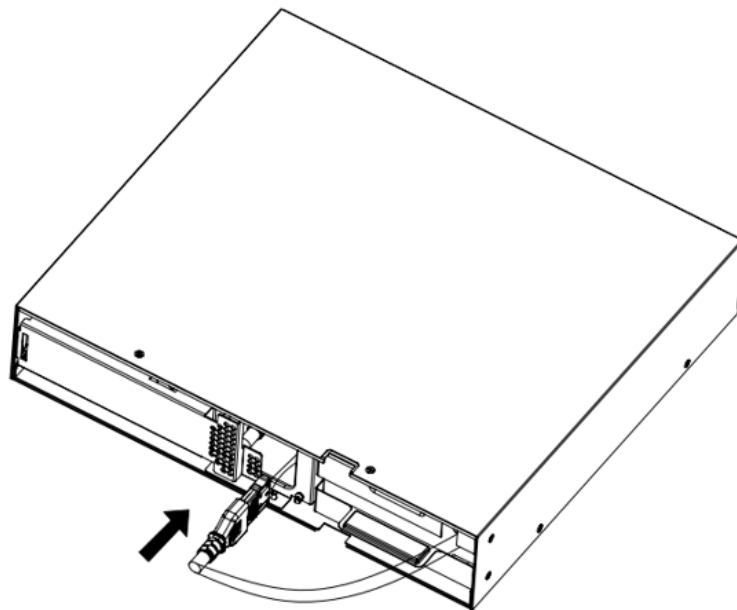

**Figure 15: Connect the First Internal Battery Cartridge Connector**

12. Insert the connectors back into the middle hole on the chassis.
13. Reinstall the faceplate on the EBP, by aligning the front panel latches with the holes in the front of the unit and snapping the faceplate onto the front of the EBP. Should have a positive snap of the latches on the faceplate.
14. Install the mounting brackets:
15. Remove the 2x Phillips Flat Head M4x8 screws from the front of each side the EBP and retain.
16. Align the mounting brackets with the screw holes on each side of the EBP and secure with the previously removed Phillips Flat Head M4x8 screws (see Figure 16).

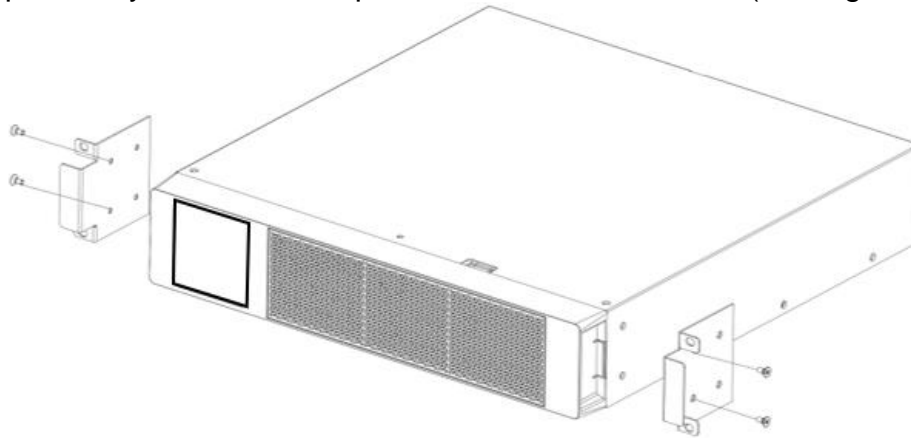

**Figure 16: Install the Mounting Bracket**

17. After installing the mounting brackets onto the EBP, slide the EBP into the rack on the rail kit (see Figure 17).

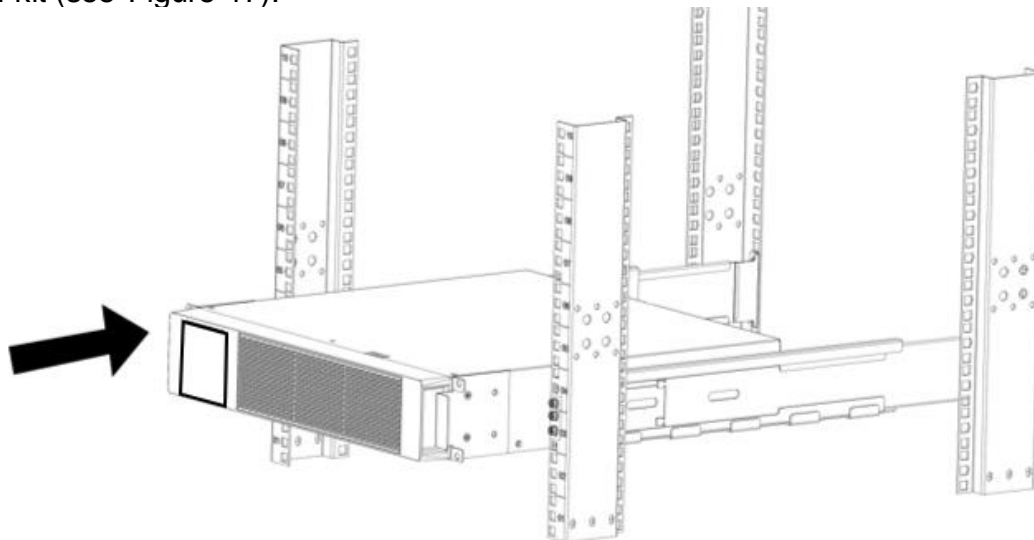

**Figure 17: Slide EBP into the Rack**

- Align the mounting brackets with the screw holes on the rack and secure the EBP with the supplied 4x Phillips Hex Head M5 screws (see Figure 18).

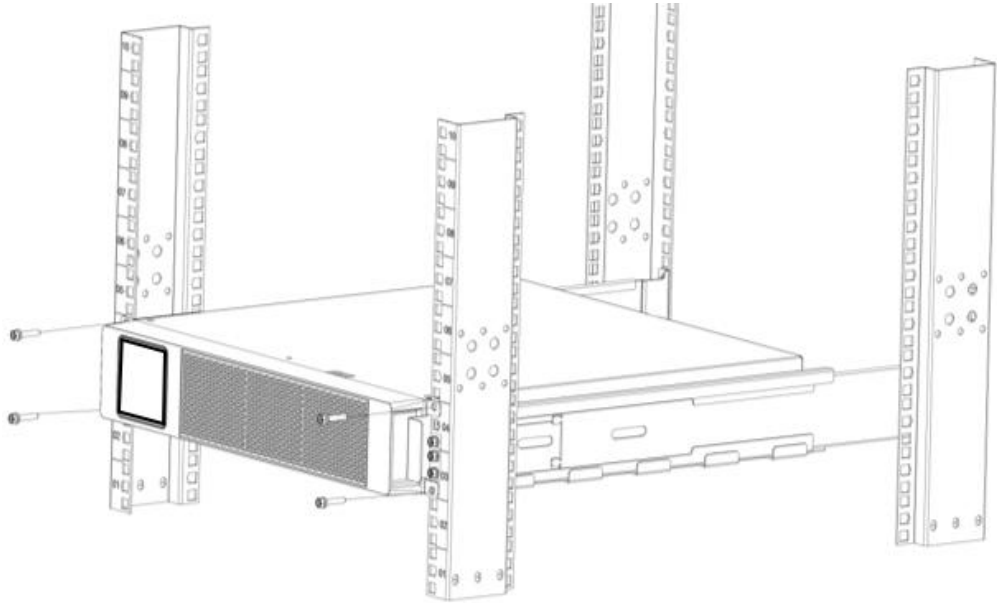

**Figure 18: Secure the Mounting Brackets to the Rack**

*3U UPS Units (U05N11V, U05S11V, U06N11V, U06S11V, U06N12V, U06S12V, U10N11V, U10S11V, U10N12V, U10S12V, U10N32V, U10S32V, U15N32V, U15S32V, U20N32V, U20S32V)*

- Install the rail kit:
- Install the front side of the rail kit with 3x Phillips Pan Head M5 screws (see Figure 19) on each rail. Do not tighten the screws.

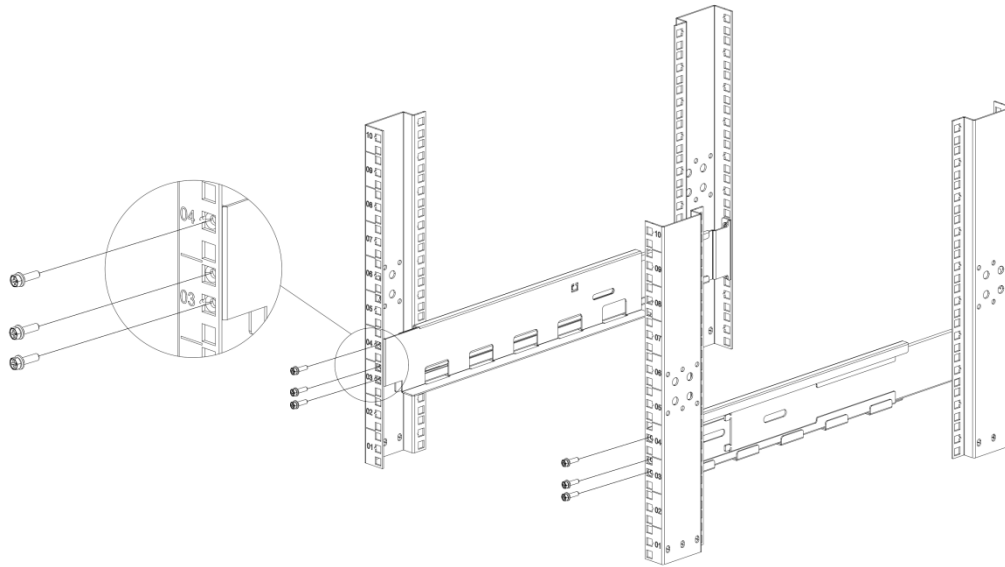

**Figure 19: Install the Front Side of Rails**

3. Adjust the rail size according to the depth of the rack
4. Assemble the rear side of the rail kit with 3x Phillips Pan Head M5 screws (see Figure 20) on each rail.

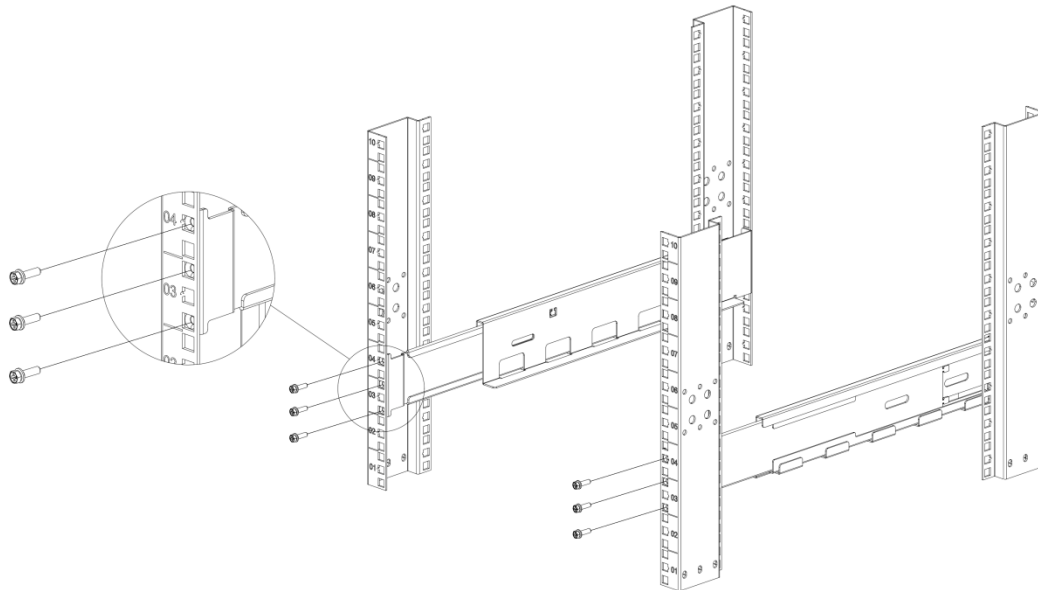

**Figure 20: Install the Rear Side of Rails**

5. Tighten all 12x screws to secure the rail kit to the rack.
6. Install the 4x cage nuts in the rack front equipment rail, with square holes. One in each of the first locations below the bottom rail kit screw and one in each of the third

locations above the top rail kit screw (see Figure 21).

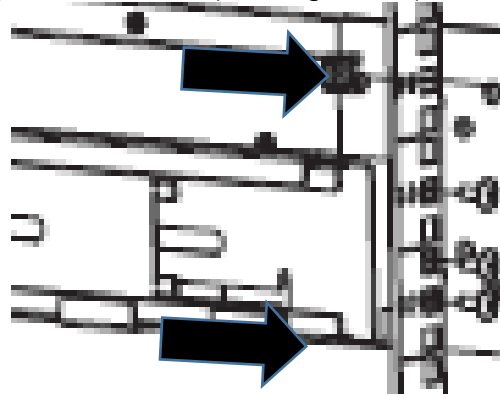

**Figure 21: Install Cage Nuts in the Front Equipment Rail with Square Holes**

7. Install the mounting brackets:
8. Remove the 4x Phillips Flat Head M4x8 screws from the front of each side the UPS and retain.
9. Align the mounting brackets with the screw holes on each side of the UPS and secure with the previously removed Phillips Flat Head M4x8 screws (see Figure 22).

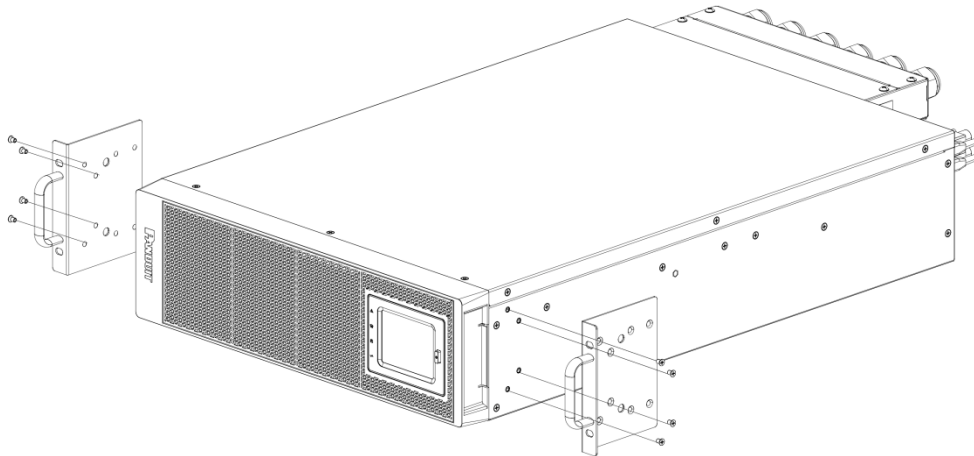

**Figure 22: Install the Mounting Bracket**

10. After installing the mounting brackets onto the UPS, slide the UPS into the rack on the rail kit (see Figure 23).

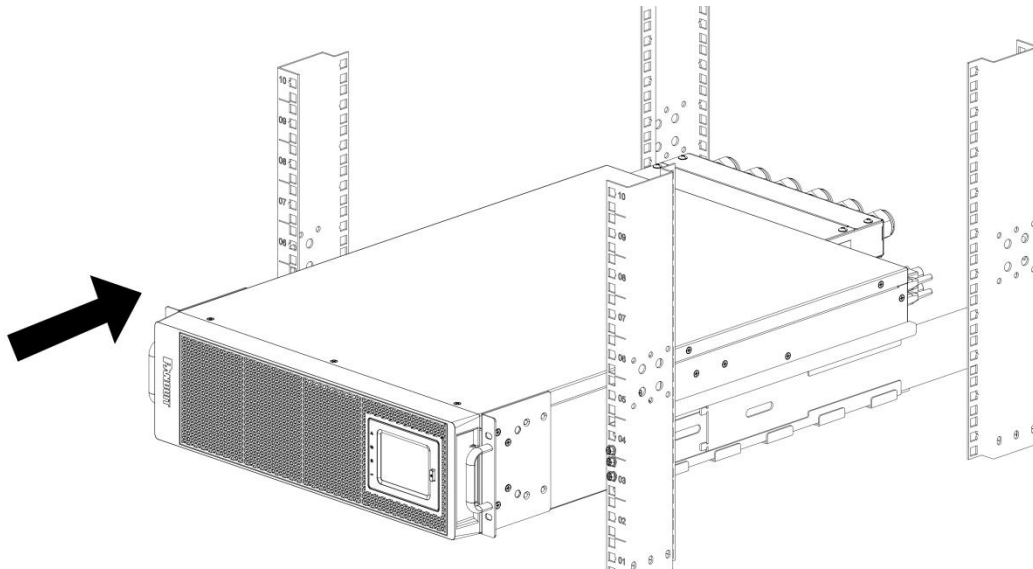

**Figure 23: Slide UPS into the Rack**

11. Align the mounting brackets with the screw holes on the rack and secure the UPS with the supplied 4x Phillips Hex Head M5 screws (see Figure 24).

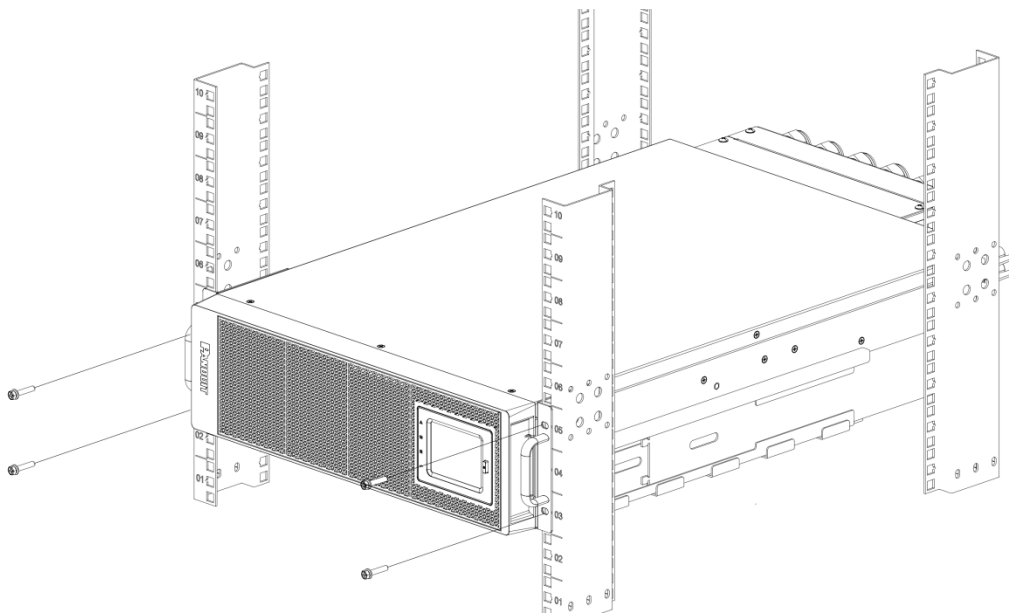
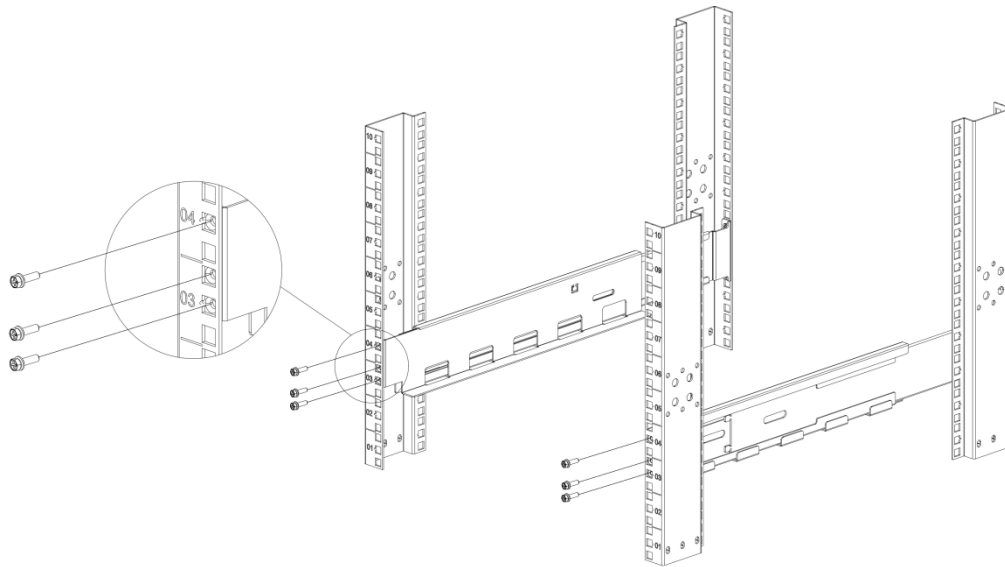

**Figure 24: Secure the Mounting Brackets to the Rack**

### 3U EBP Unit (UVP240)

It is recommended to install the EBP directly under the UPS. It is recommended to install all subsequent EBPs directly under the previous EBP.

1. Install the rail kit:
12. Install the front side of the rail kit with 3x Phillips Pan Head M5 screws (see Figure 25) on each rail. Do not tighten the screws.



**Figure 25: Install the Front Side of Rails**

13. Adjust the rail size according to the depth of the rack
14. Assemble the rear side of the rail kit with 3x Phillips Pan Head M5 screws (see Figure 26) on each rail.

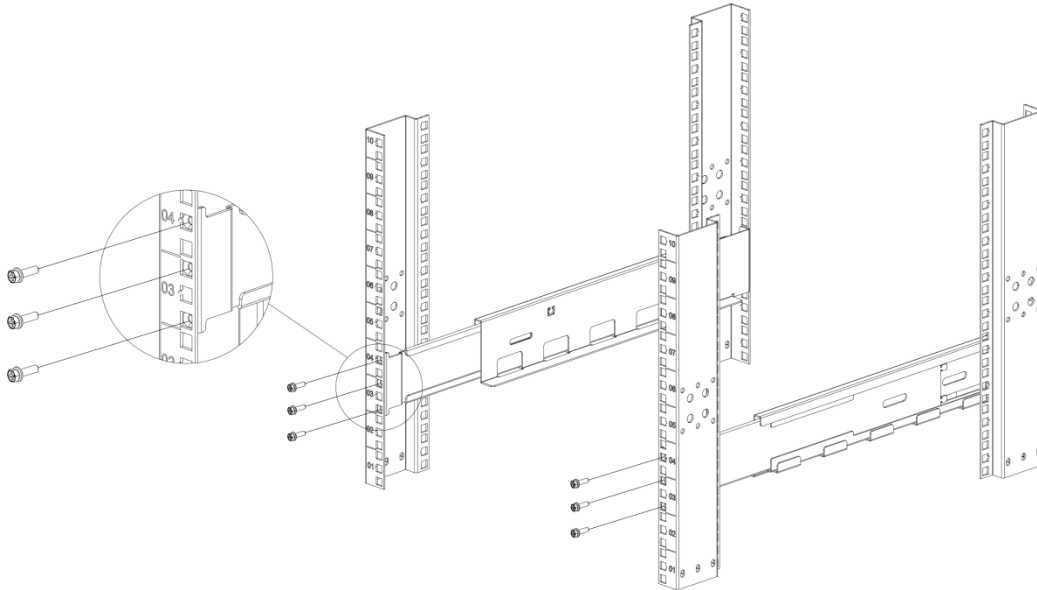

**Figure 26: Install the Rear Side of Rails**

15. Tighten all 12x screws to secure the rail kit to the rack.
16. Install the 4x cage nuts in the rack front equipment rail, with square holes. One in each of the first locations below the bottom rail kit screw and one in each of the third locations above the top rail kit screw (see Figure 27).

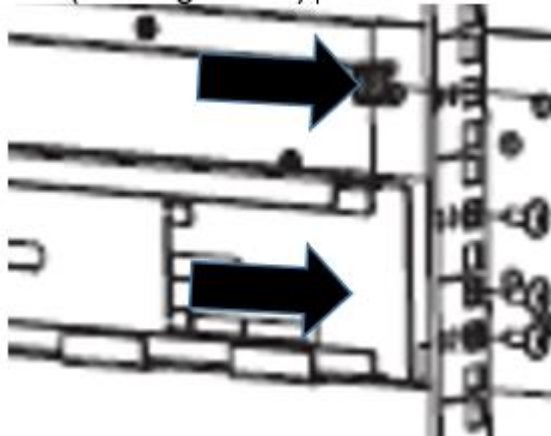

**Figure 27: Install Cage Nuts in the Front Equipment Rail with Square Holes**

17. Remove the faceplate:
18. Press both sides of EBP faceplate until the latches release (see Figure 28). Then remove the faceplate form the front of the unit.



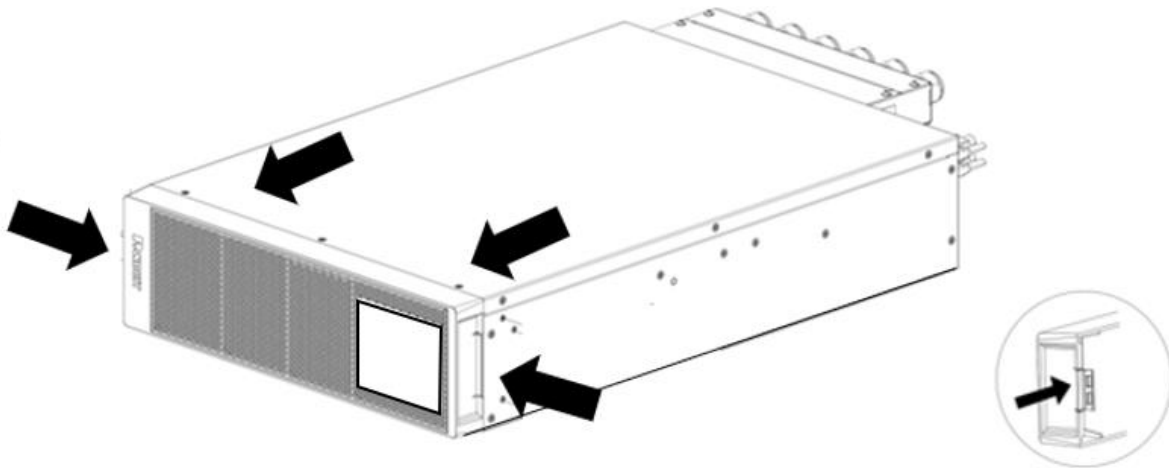

**Figure 28: Press the Latches to Remove Faceplate**

19. Install the mounting brackets:
20. Remove the 4x Phillips Flat Head M4x8 screws from the front of each side the EBP and retain.
21. Align the mounting brackets with the screw holes on each side of the EBP and secure with the previously removed Phillips Flat Head M4x8 screws (see Figure 29).

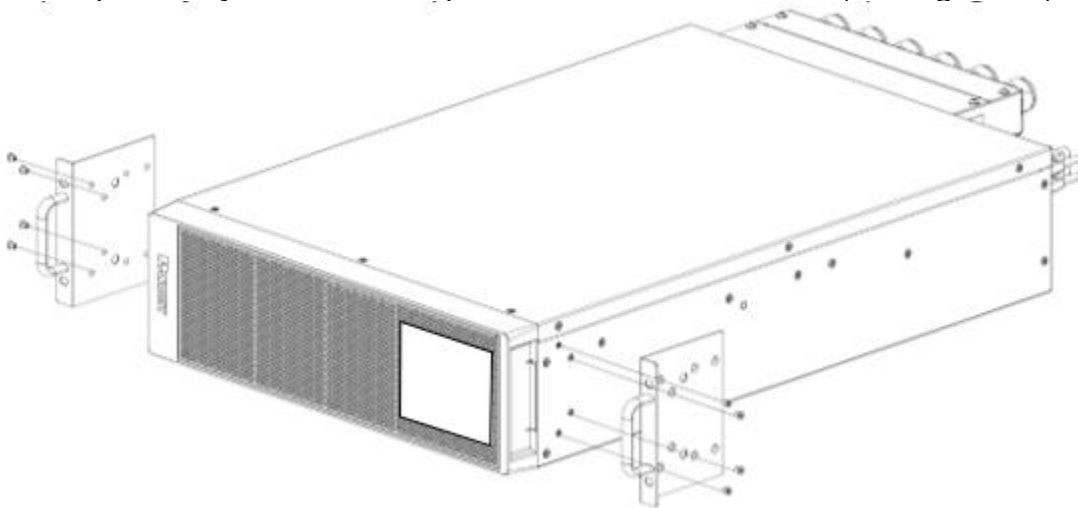

**Figure 29: Install the Mounting Bracket**

22. Disconnect all three battery cartridge connectors (see Figure 30).

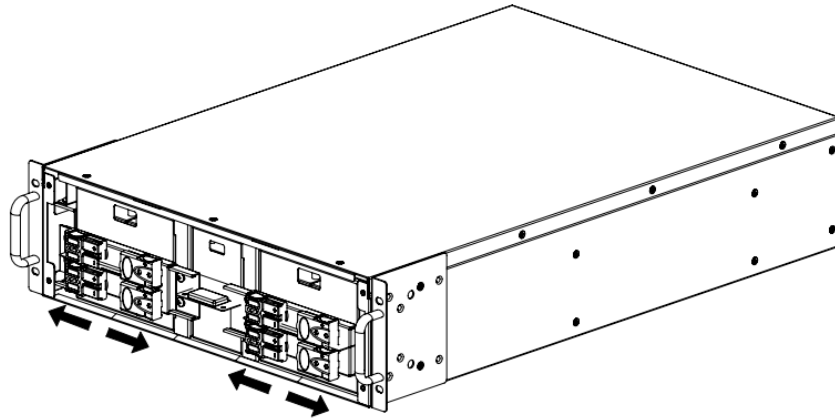

**Figure 30: Disconnect Internal Battery Cartridges**

23. Remove the battery baffle screws and baffles and retain (see Figure 31).

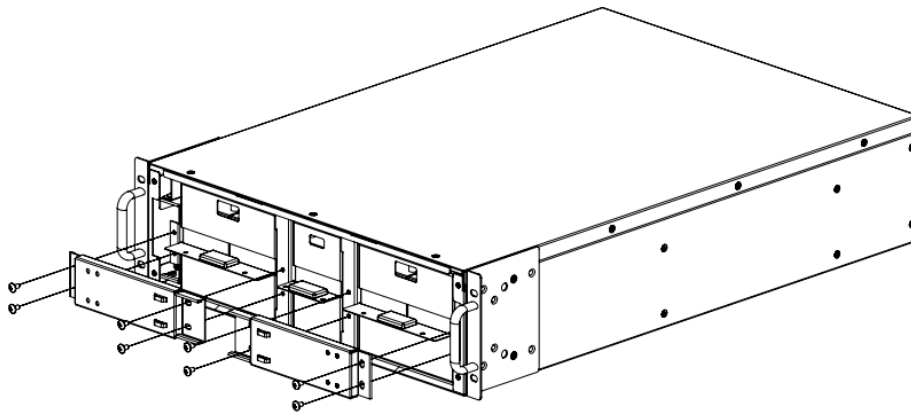

**Figure 31: Remove the Battery Baffles**

24. Refer to the handling instruction, take out all three battery cartridges (see Figure 32). Two larger battery cartridges and one smaller battery cartridge.

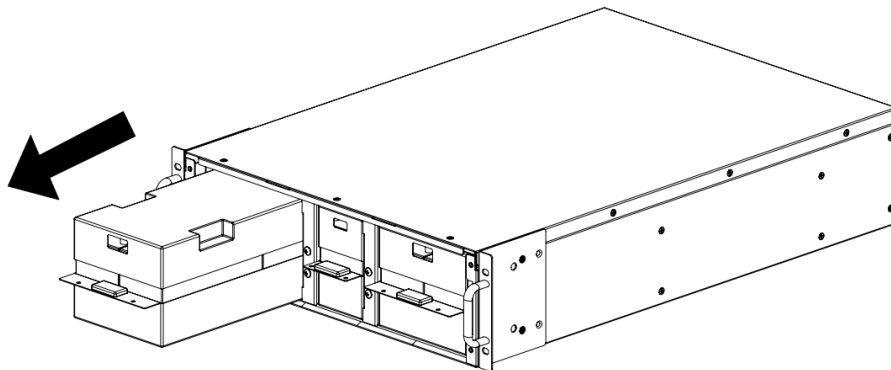

**Figure 32: Remove Battery Cartridges from EBP**

25. Slide the EBP into the rack on the rail kit (see Figure 33).

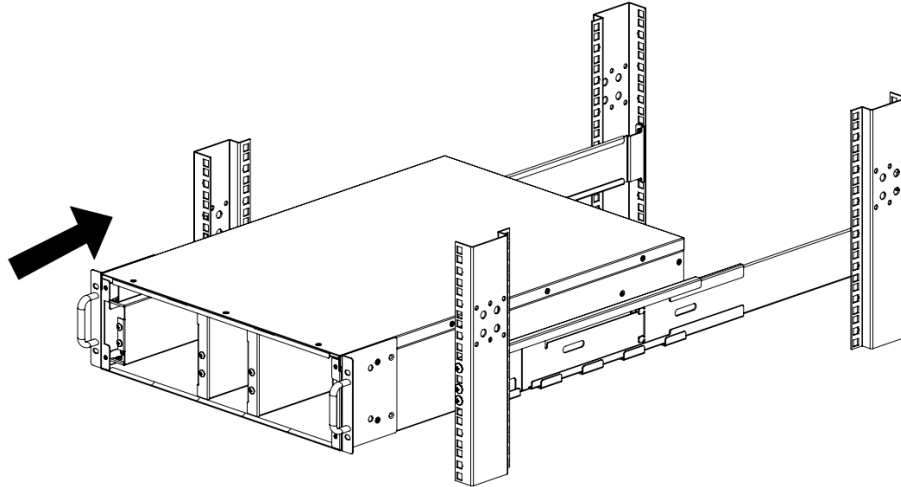

**Figure 33: Slide EBP into the Rack**

26. Align the mounting brackets with the screw holes on the rack and secure the EBP with the supplied 4x Phillips Hex Head M5 screws (see Figure 34).

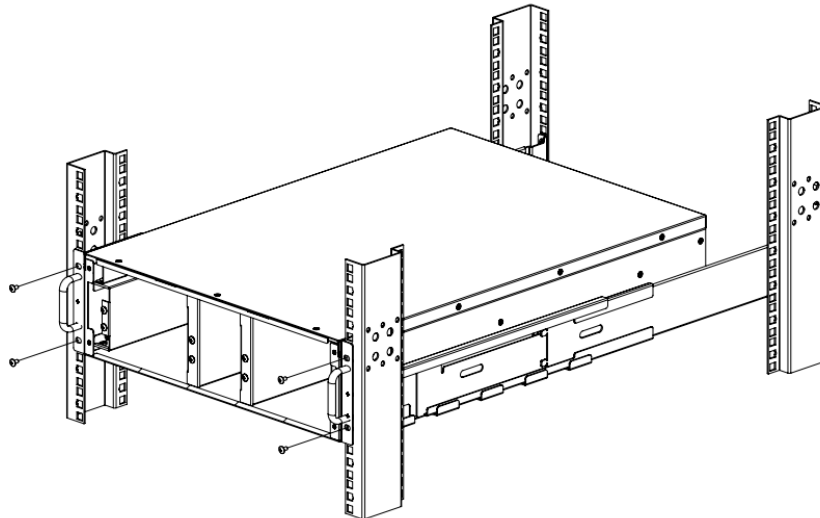

**Figure 34: Secure the Mounting Brackets to the Rack**

27. Refer to the handling instruction, reinsert the battery cartridges into the EBP unit (see Figure 35).

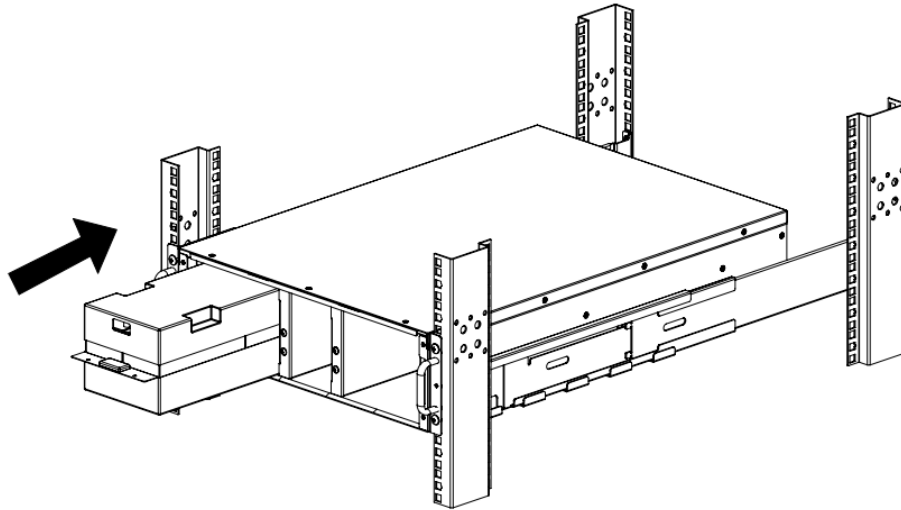

**Figure 35: Reinsert the Battery Cartridges into the EBP Unit**

28. Reinstall the battery baffles the screws (see Figure 36).

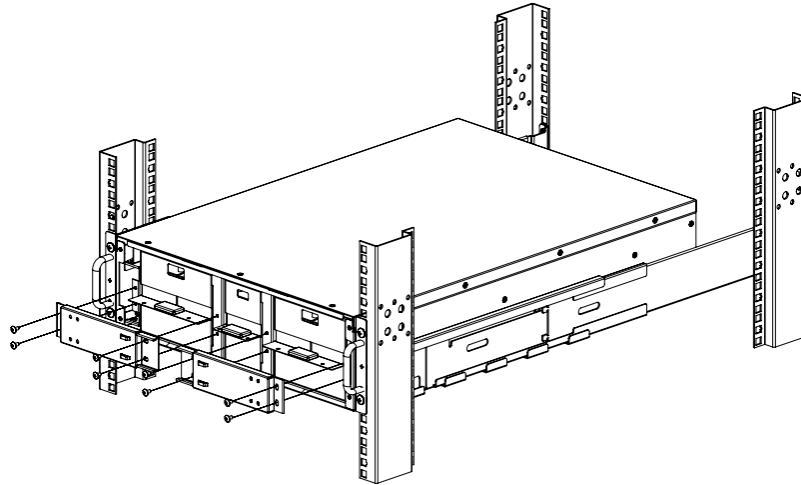

**Figure 36: Reinstall Battery Baffles and Screws**

29. Reconnect the Battery Cartridge connectors (see Figure 37). Press each connector tightly together to ensure a proper connection.

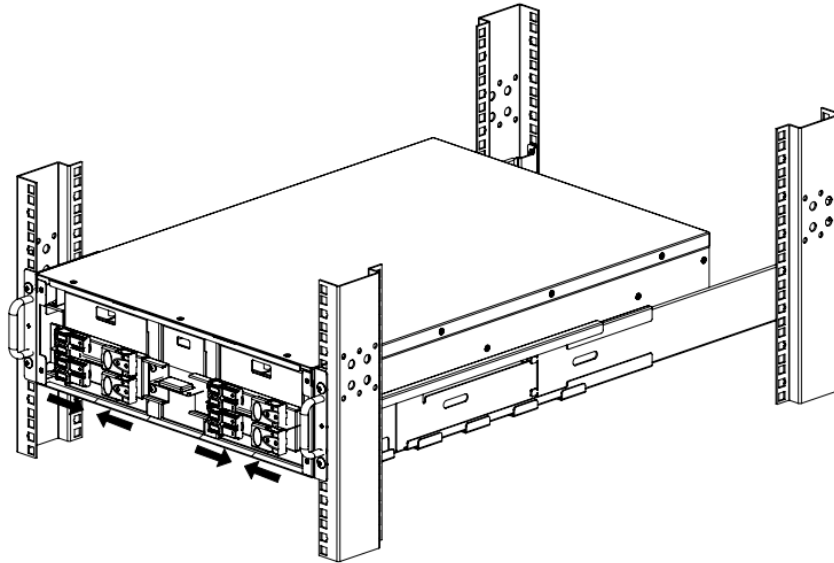

**Figure 37: Reconnect EBP Battery Cartridge Connectors**

30. Reinstall the faceplate on the EBP, by aligning the front panel latches with the holes in the front of the unit and snapping the faceplate onto the front of the EBP. Should have a positive snap of the latches on the faceplate.

*3U MBS Unit (UMB20K)*

It is recommended to install the MBS directly above the UPS.

1. Install the rail kit:
  31. Install the front side of the rail kit with 3x Phillips Pan Head M5 screws (see Figure 38) on each rail. Do not tighten the screws.

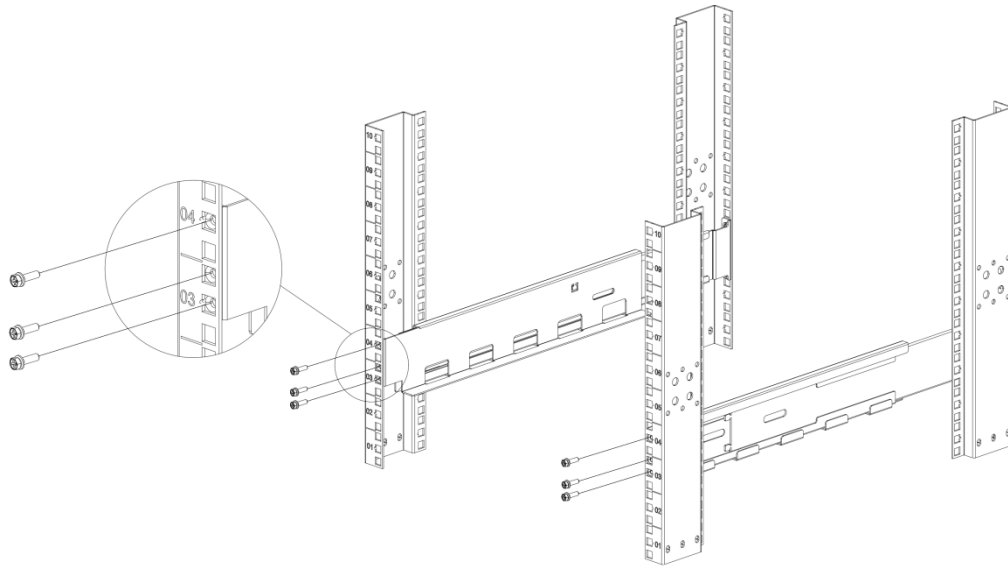

**Figure 38: Install the Front Side of Rails**

32. Adjust the rail size according to the depth of the rack
33. Assemble the rear side of the rail kit with 3x Phillips Pan Head M5 screws (see Figure 39) on each rail.

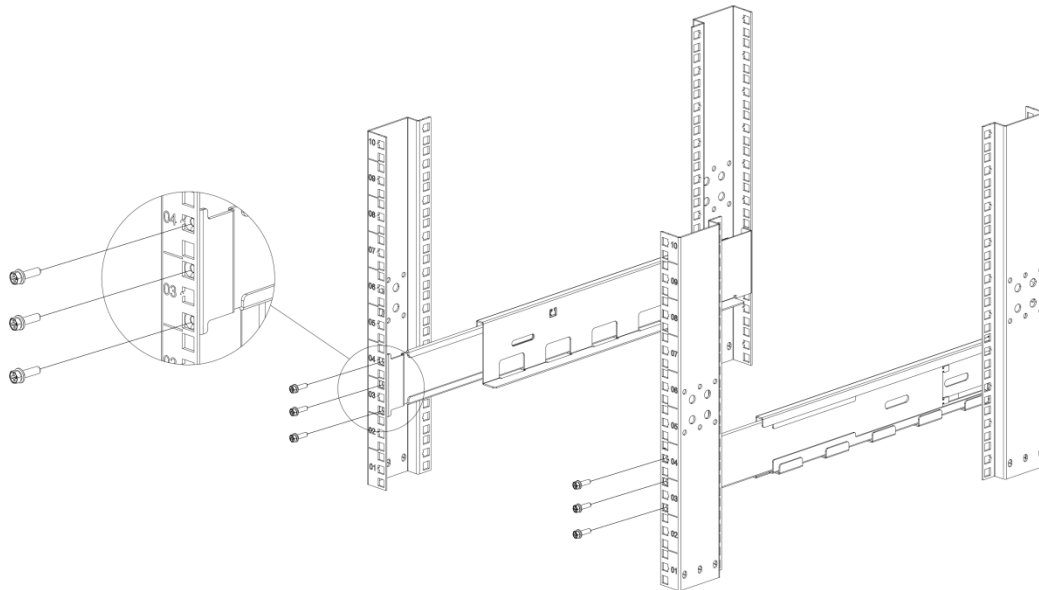

**Figure 39: Install the Rear Side of Rails**

34. Tighten all 12x screws to secure the rail kit to the rack.
35. Install the 4x cage nuts in the rack front equipment rail, with square holes. One in each of the first locations below the bottom rail kit screw and one in each of the third

locations above the top rail kit screw (see Figure 40).

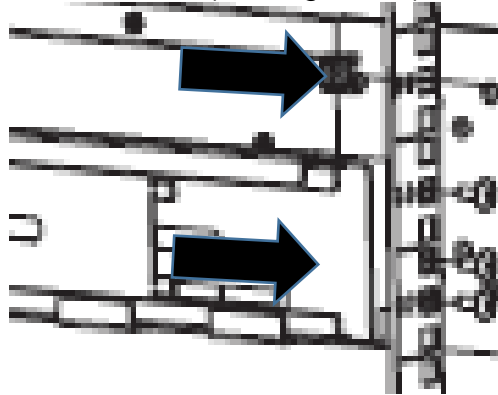

**Figure 40: Install Cage Nuts in the Front Equipment Rail with Square Holes**

36. Install the mounting brackets:
37. Remove the 2x Phillips Flat Head M4x8 screws from the front of each side the MBS and retain.
38. Align the mounting brackets with the screw holes on each side of the MBS and secure with the previously removed Phillips Flat Head M4x8 screws (see Figure 41).

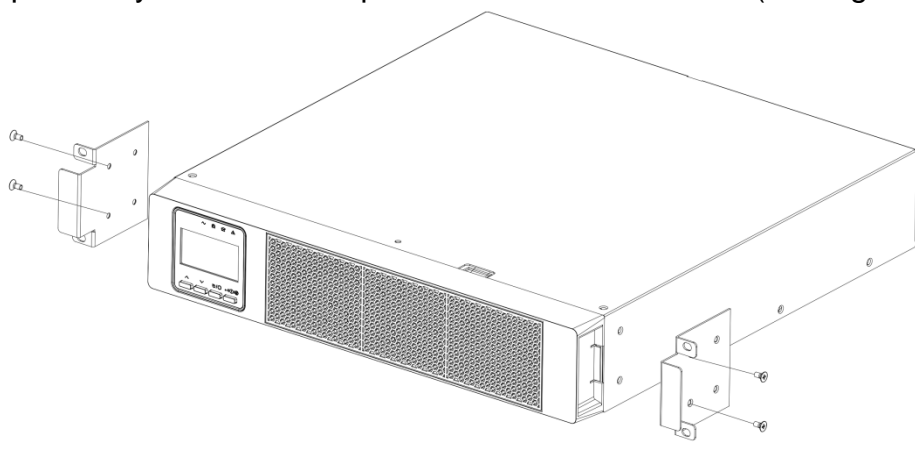

**Figure 41: Install the Mounting Bracket MBS**

39. After installing the mounting brackets onto the MBS, slide the MBS into the rack on the rail kit (see Figure 42).

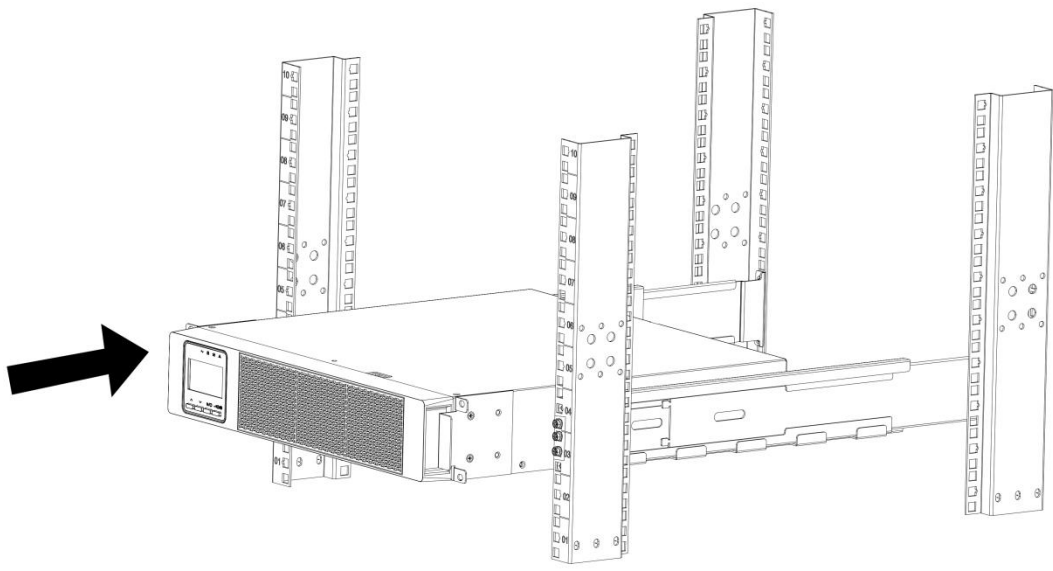

**Figure 42: Slide MBS into the Rack MBS**

40. Align the mounting brackets with the screw holes on the rack and secure the MBS with the supplied 4x Phillips Hex Head M5 screws (see Figure 43).

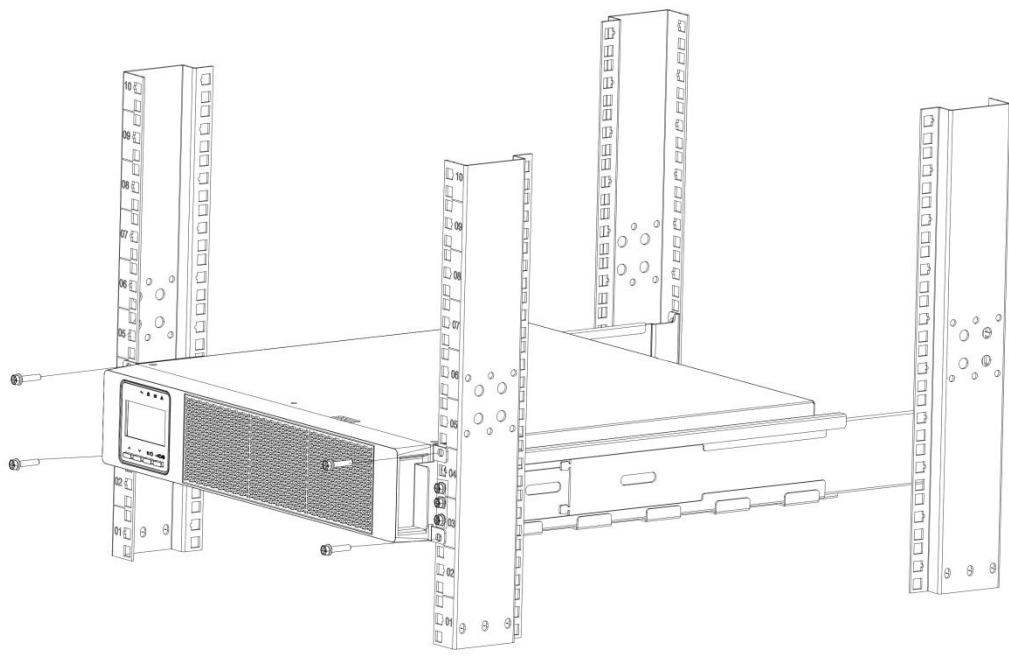

**Figure 43: Secure the Mounting Brackets to the Rack MBS**



### 4U EBP Unit (UVP480)

It is recommended to install the EBP directly under the UPS. It is recommended to install all subsequent EBPs directly under the previous EBP.

1. Install the rail kit:
  41. Install the front side of the rail kit with 2x Phillips Pan Head M5X12 screws (see Figure 44) on each rail. Do not tighten the screws.

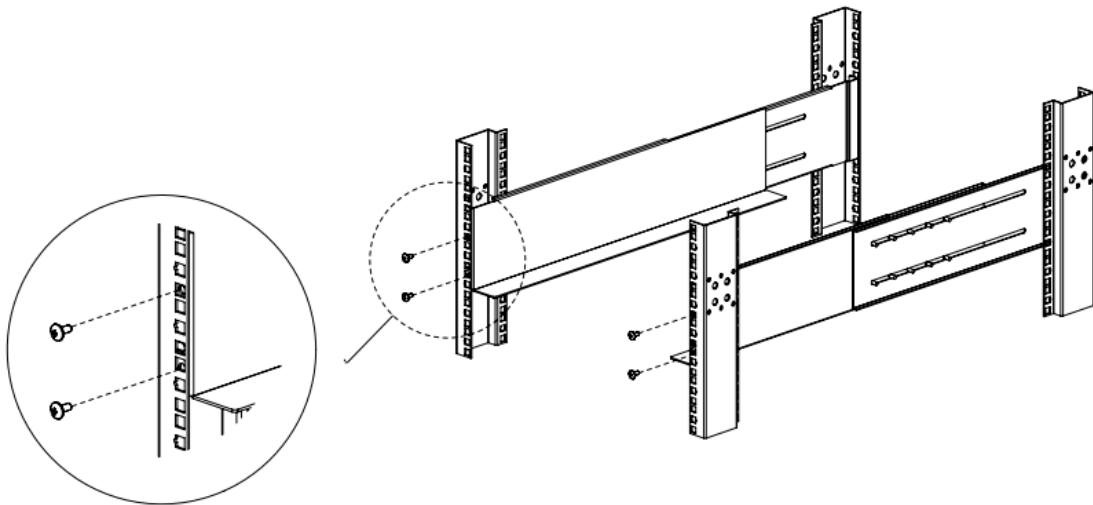

**Figure 44: Install the Front Side of Rails**

42. Adjust the rail size according to the depth of the rack
43. Assemble the rear side of the rail kit with 2x Phillips Pan Head M5X12 screws (see Figure 45) on each rail.

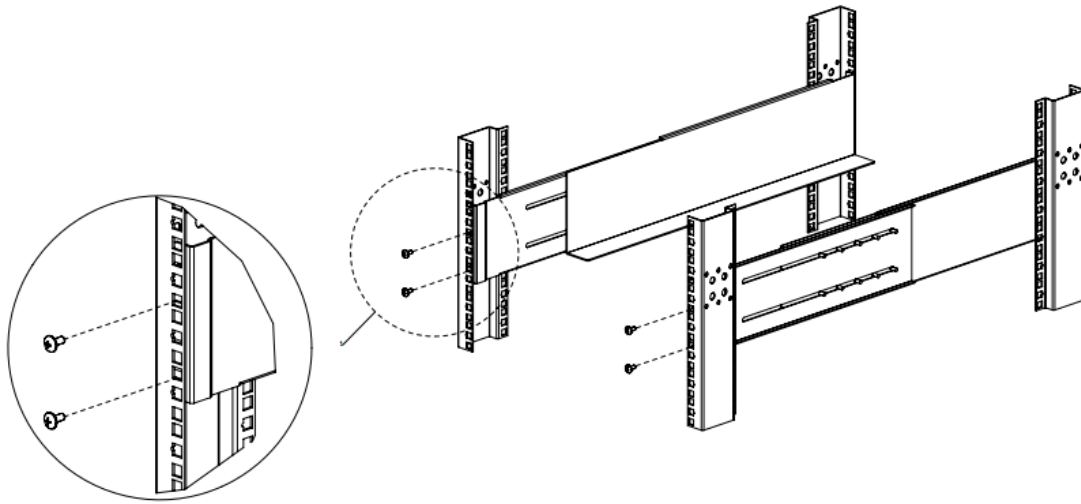

**Figure 45: Install the Rear Side of Rails**

- 44. Tighten all 8x screws to secure the rail kit to the rack.
- 45. Remove the faceplate:
- 46. Press both sides of EBP faceplate until the latches release (see Figure 46). Then remove the faceplate from the front of the unit.

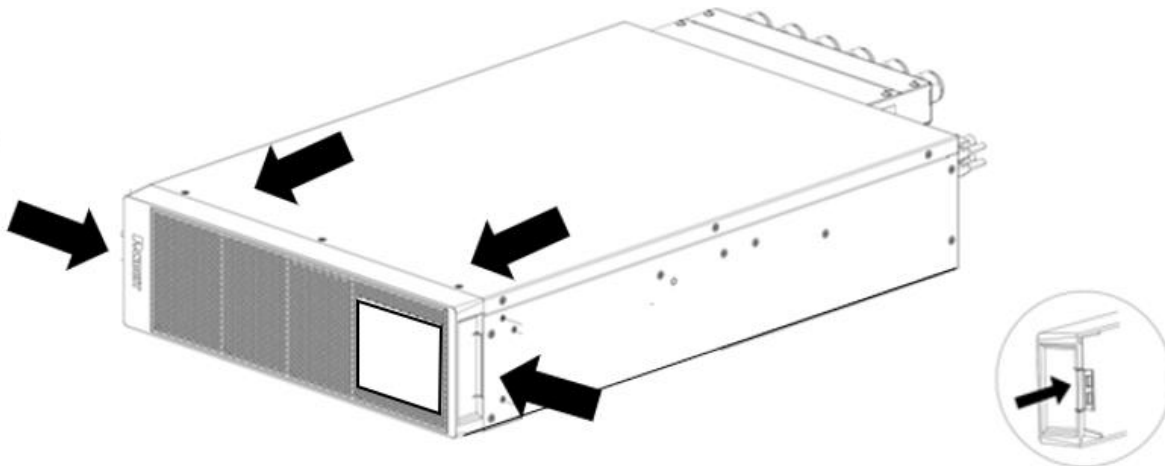

**Figure 46: Press the Latches to Remove Faceplate**

- 47. Remove the screws and battery baffle from EBP (see Figure 46).

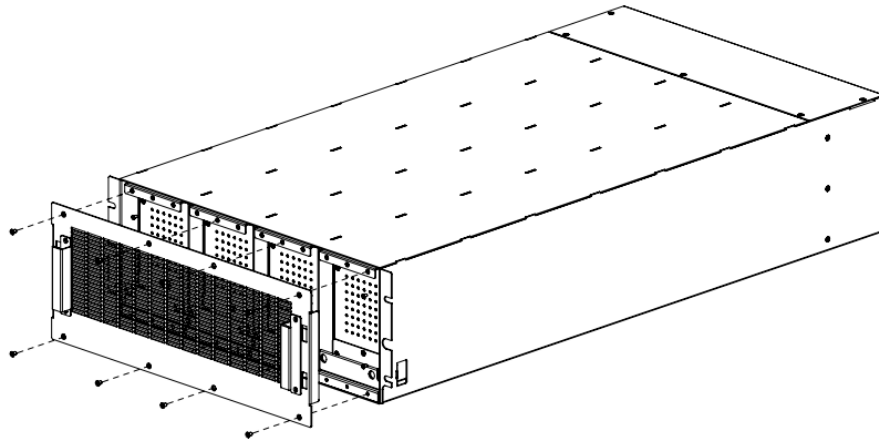

**Figure 46: Remove Battery Baffle on the EBP**

48. Refer to the handling instruction, remove all battery cartridges (see Figure 47).

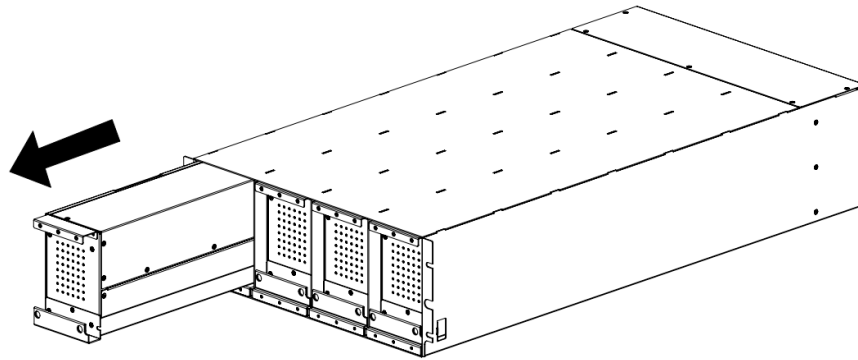

**Figure 47: Remove Battery Cartridges from EBP**

49. Slide the EBP into the rack on the rail kit (see Figure 48).

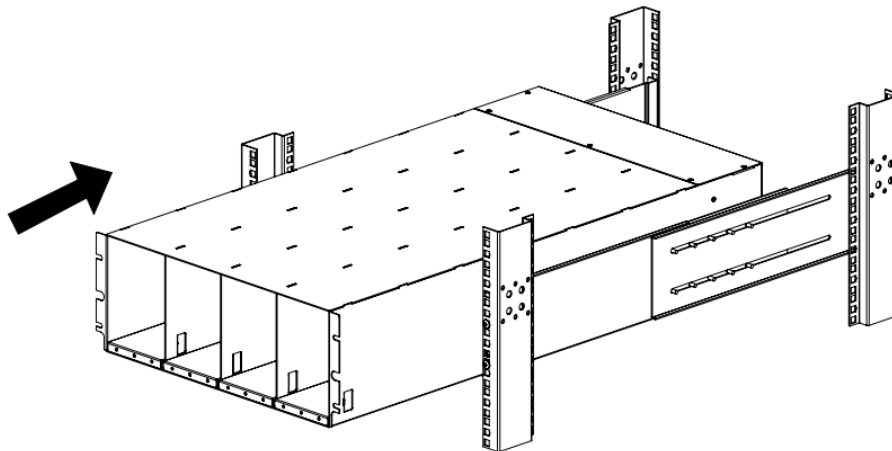

**Figure 48: Slide EBP into Rack**

50. Align the mounting brackets with the screw holes on the rack and secure the EBP with the supplied 4x Phillips Hex Head M5 screws (see Figure 49).

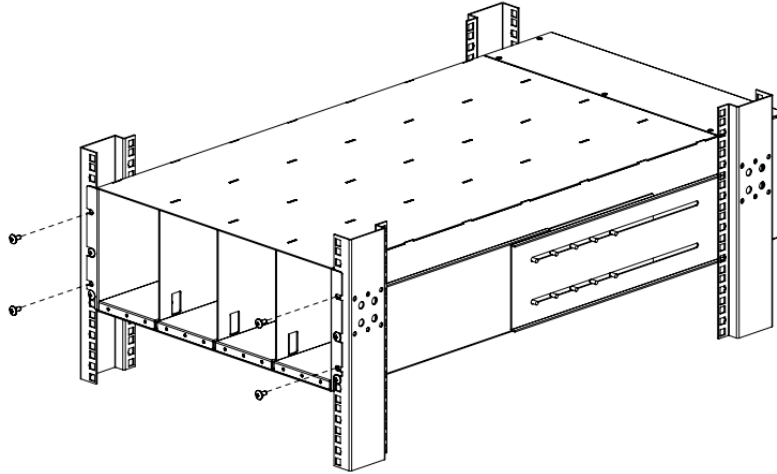

**Figure 49: Secure the Mounting Brackets to the Rack**

51. Refer to the handling instruction, reinsert all four battery cartridges into the EBP (see Figure 50).

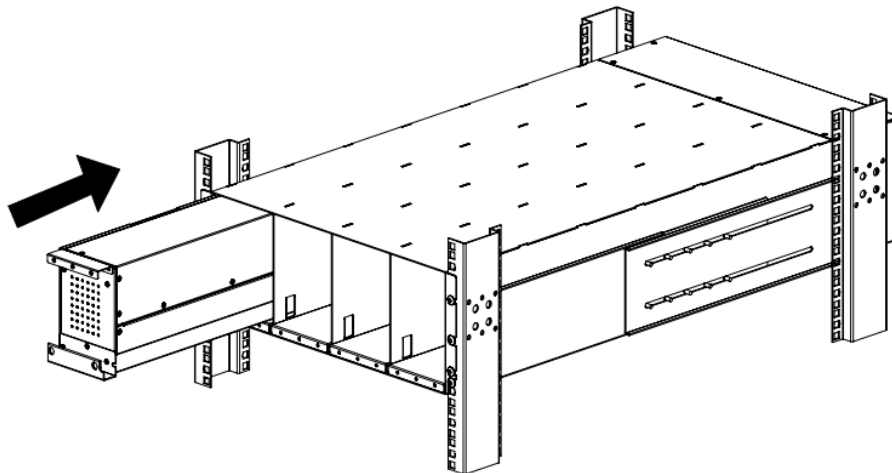

**Figure 50: Reinsert the Battery Cartridges into the EBP**

52. Install and secure the screws on the battery baffles (see Figure 51).

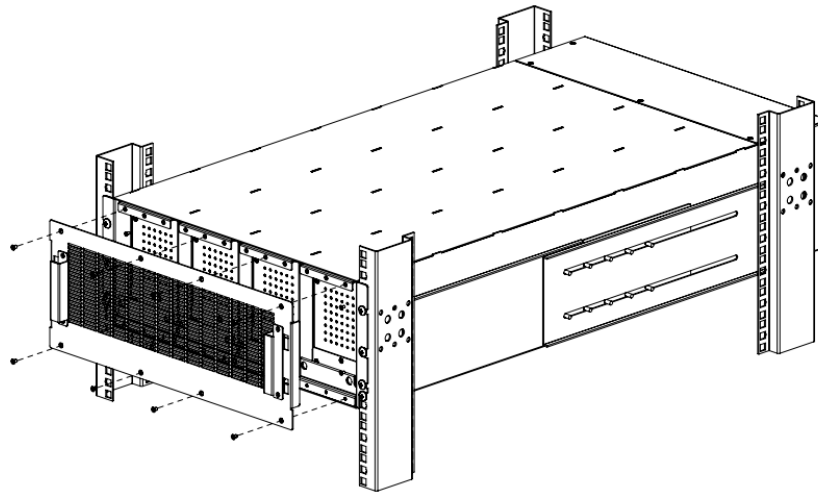

**Figure 51: Reinstall the EBP Battery Baffle**

53. Reinstall the faceplate on the EBP, by aligning the front panel latches with the holes in the front of the unit and snapping the faceplate onto the front of the EBP. Should have a positive snap of the latches on the faceplate.

## Two-Post Racks

Additional hardware is required for installation in a standard EIA two-post rack with threaded mounting holes. The appropriate rack mount shelf would need to be used for this mounting technique. Please refer to the [Panduit Rack Mount Shelves specification](#) on the Panduit website for the appropriate shelf to use with each unit. (Note: The unit is not secured to the rack in this technique, it is just set on the shelf).

### CAUTION



- *The units are heavy. Removing the units from its carton requires a minimum of two people.*
- *The 3-phase EBP (UVP480) cannot be mounted in a two-post rack, there is no shelf to support the weight of this unit. The weight of this unit would also make the two-post rack unstable.*
- *If installing optional EBP(s), make sure to install the EBP(s) directly below the UPS so that all wiring between the units can use the wiring provided with the units.*

**NOTE:** *Mounting shelves are required for each individual unit.*

## Tower

The tower mounting is not a preferred recommended mounting technique for the UPS,

EBP and MBS units. However, the mounting hardware for this technique is provided with most units. The 3-Phase UPS and EBP unit should not use this mounting technique due to physical configuration and physical weight of the unit.

**CAUTION**



- *The unit is heavy. Removing the unit from its carton requires a minimum of two people.*
- *If installing optional EBP(s), make sure to install the EBP(s) directly next to the UPS so that all wiring between the units can use the wiring provided with the units.*

**NOTE:** *Tower mounting stands are required for each individual unit.*

**2U Units (U01N11V, U01S11V, U01N12V, U01S12V, U01N13V, U01S13V, U02N11V, U02S11V, U02N12V, U02S12V, U03N11V, U03S11V, U03N12V, U03S12V, UVP024, UVP036, UVP048, UVP072)**

1. Assemble the tower kit (see Figure 52).

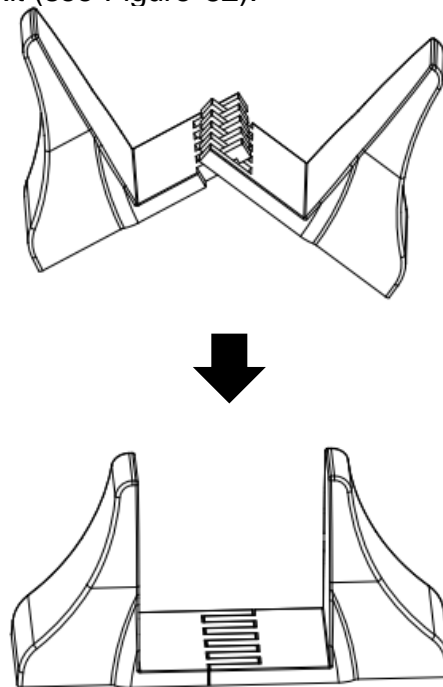

**Figure 52: Tower Kit for 2U Units**

2. Before the installation of the UPS faceplate, place the unit into the tower kit, for UPS units manually rotate the LCD panel to vertical display (see Figure 53). The EBP Battery Pack signage does not rotate.

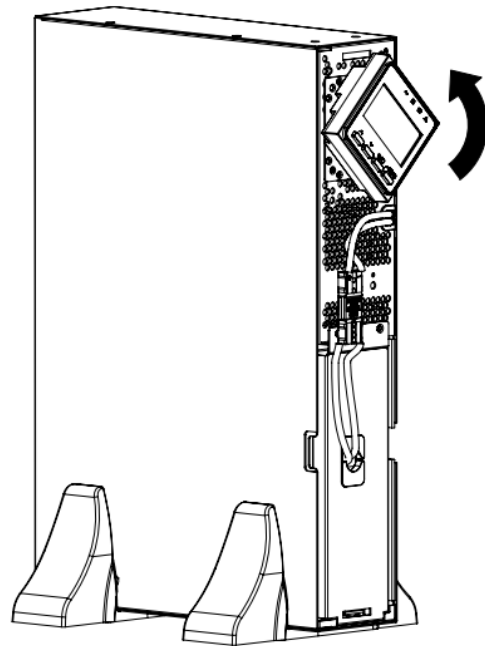

**Figure 53: Manually Rotate the Display on the 1-3kVA UPS Units**

- a) Install the faceplate on the UPS, by aligning the front panel display through the hole in the faceplate and snapping the faceplate onto the front of the UPS. Should have a positive snap of the latches on the faceplate (see Figure 54).
- b) Install the faceplate on the EBP, by aligning the front panel latches with the holes in the front of the unit and snapping the faceplate onto the front of the EBP. Should have a positive snap of the latches on the faceplate.

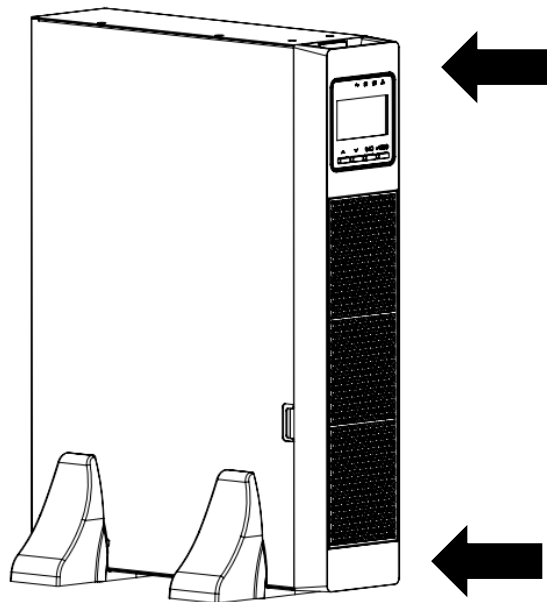

**Figure 54: Example of Snapping the Faceplate onto the Front of the UPS 3U Units (U05N11V, U05S11V, U06N11V, U06S11V, U06N12V, U06S12V, U10N11V, U10S11V, U10N12V, U10S12V, UVP240)**

1. Assemble the tower kit with one extender in each support (see Figure 455).

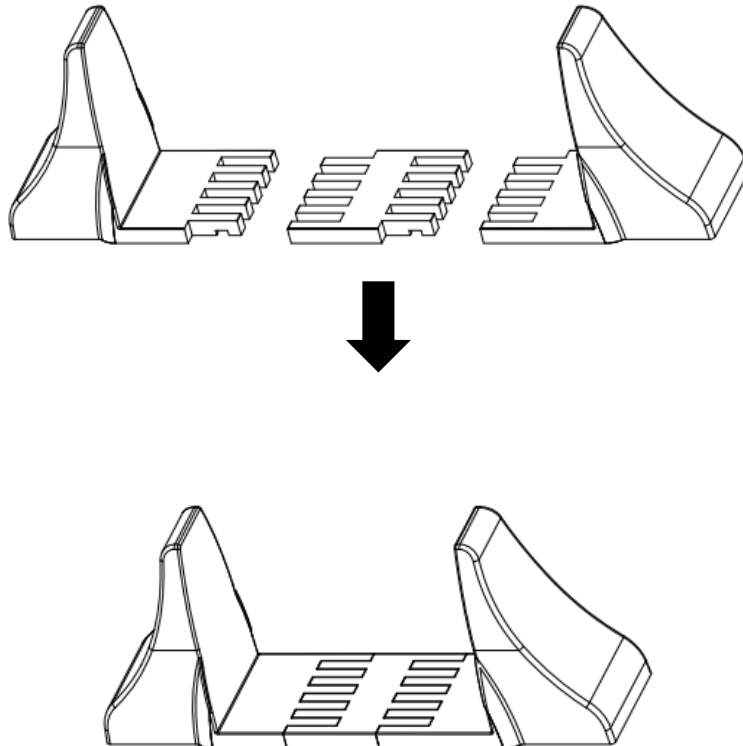

**Figure 55: Tower Kit for 3U Units**

2. Place the unit into the tower kit, for UPS and EBP units neither the LCD panel nor Battery Pack signage rotates.
3. Install the faceplate on the unit, by aligning the front panel latches with the holes in the front of the unit and snapping the faceplate onto the front of the unit. Should have a positive snap of the latches on the faceplate (see Figure 56).



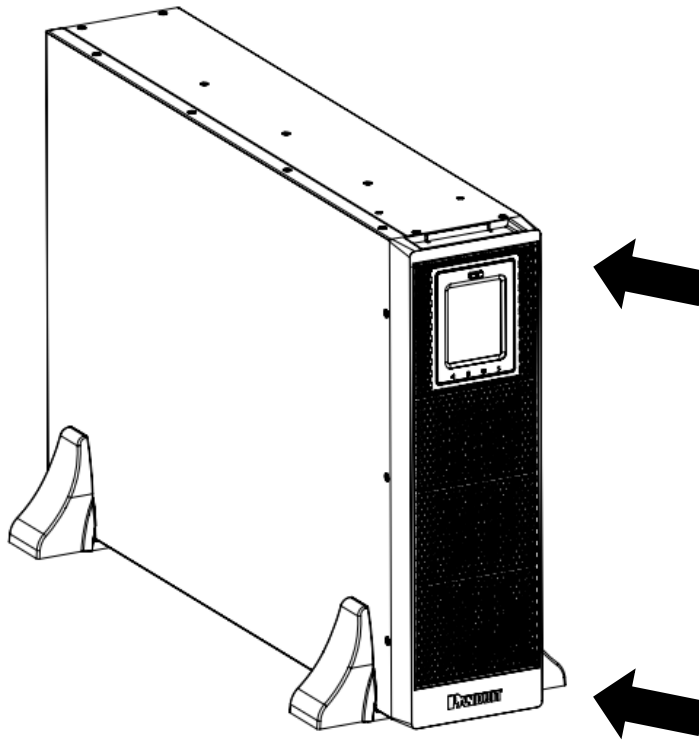

**Figure 56: Example of Snapping the Faceplate onto the Front of the UPS 3-Phase Units (U10N32V, U10S32V, U15N32V, U15S32V, U20N32V, U20S32V, UVP480, UMB20K)**

The UVP480 cannot be tower mounted due to physical constraints. Since this is the battery for all 3-phase units, it is not recommended to tower mount any 3-phase units.

## Section 4 – Electrical Connections

The UPS, EBP and the MBS have different electrical connections. Refer to the following section that matches the UPS system that is being deployed. For safety reasons all UPS units require an external circuit breaker at the input A.C. supply

### **1-10kVA Single Phase UPS and Associated EBP (U01N11V, U01S11V, U01N12V, U01S12V, U01N13V, U01S13V, U02N11V, U02S11V, U02N12V, U02S12V, U03N11V, U03S11V, U03N12V, U03S12V, U05N11V, U05S11V, U06N11V, U06S11V, U06N12V, U06S12V, U10N11V, U10S11V, U10N12V, U10S12V, UVP024, UVP036, UVP048, UVP072, UVP240)**

1. Connect the UPS to the input source.
54. These UPS units will either have an input power cord with a plug or an input hardwire connections.
55. The 1-5kVA UPS units have an input power cord with a plug that interfaces with the region's standard outlets (U01N11V, U01S11V, U01N12V, U01S12V, U01N13V, U01S13V, U02N11V, U02S11V, U02N12V, U02S12V, U03N11V, U03S11V, U03N12V, U03S12V, U05N11V, U05S11V).
56. The 6-10kVA UPS units have a hardwire input (U06N11V, U06S11V, U06N12V, U06S12V, U10N11V, U10S11V, U10N12V, U10S12V).
57. For units with an input power plug, properly insert the plug into the region's standard outlet. NOTE: Each part of the system must maintain a connected earth ground.
58. For units with a hardwire input, ensure that there is no power to the wires, use lock-out tag-out at the breaker panel. The wire used for all three conductors should be 10mm<sup>2</sup>. This wire must conform to the local wiring code according to environmental conditions (temperature and natural conditions). NOTE: Each part of the system must maintain a connected earth ground.
59. Remove the small protective cover on the terminal block on the back of the UPS.
60. It is recommended that you use a power cord with 10mm<sup>2</sup> wires.
61. Crimp a ring terminal onto each wire with a standard crimping tool for 10 mm<sup>2</sup> wire.
62. Connect each wire under the appropriate screw as indicated on the back of the UPS. NOTE: Each part of the system must maintain a connected earth ground.
63. After completing the wiring, confirm again that all wiring is correct.
64. Leave the terminal block cover off the rear panel for the next step of connecting the load(s).
65. Connect the load(s) to the UPS
66. These UPS units will either have output outlets or output outlets and output hardwire connections.

67. The 1-5kVA UPS units have region standard outlets (U01N11V, U01S11V, U01N12V, U01S12V, U01N13V, U01S13V, U02N11V, U02S11V, U02N12V, U02S12V, U03N11V, U03S11V, U03N12V, U03S12V, U05N11V, U05S11V).
68. The 6-10kVA UPS units have region standard outlets and a hardwire connection (U06N11V, U06S11V, U06N12V, U06S12V, U10N11V, U10S11V, U10N12V, U10S12V).
69. For units with standard outlets, properly insert the plugs from the loads into the standard outlets. (NOTE: Outlet Groups 2 and optional 3 may be used for critical or noncritical loads, depending how the UPS system is configured. Group 1 is always used for critical loads only). NOTE: Each part of the system must maintain a connected earth ground.
70. For units with standard outlets and a hardwire output, make the hardwire connection first. The wire used for all three conductors should be 10mm<sup>2</sup>. This wire must conform to the local wiring code according to environmental conditions (temperature and natural conditions). NOTE: Each part of the system must maintain a connected earth ground.
71. The small protective cover on the terminal block should already be removed from the last step.
72. It is recommended that you use a power cord with 10mm<sup>2</sup> wires to connect to the load.
73. Crimp a ring terminal onto each wire with a standard crimping tool for 10 mm<sup>2</sup> wire.
74. Connect each wire under the appropriate screw as indicated on the back of the UPS.  
NOTE: Each part of the system must maintain a connected earth ground.
75. After completing the wiring, confirm again that all wiring is correct.
76. Replace the terminal block cover on the rear panel of the UPS.
77. Then properly insert the plugs from the loads into the standard outlets. (NOTE: Outlet Groups 2 and optional Outlet Group 3 may be used for critical or noncritical loads, depending how the UPS system is configured. Group 1 is the hardwire output and is always used for critical loads only). NOTE: Each part of the system must maintain a connected earth ground.
78. Connect the EBP(s) to the UPS
79. As indicated in the mounting section, the EBP should be mounted under or near the UPS. Plug the EBP cable(s) into the battery connector(s) as shown in Figure 57. Figure 57 is an example system, the actual UPS and EBPs that are part of the system deployed may have the battery connections in different physical locations on the back of the UPS and/or EBP then shown in this figure. Insert and press the connector tightly together to ensure a proper connection.
80. Verify that the EBP connections are tight, and the adequate bend radius and strain relief exist for each cable.
81. The 1-3kVA system may have up to 4 EBP units connected.
82. The 5-10kVA system may have up to 5 EBP units connected.

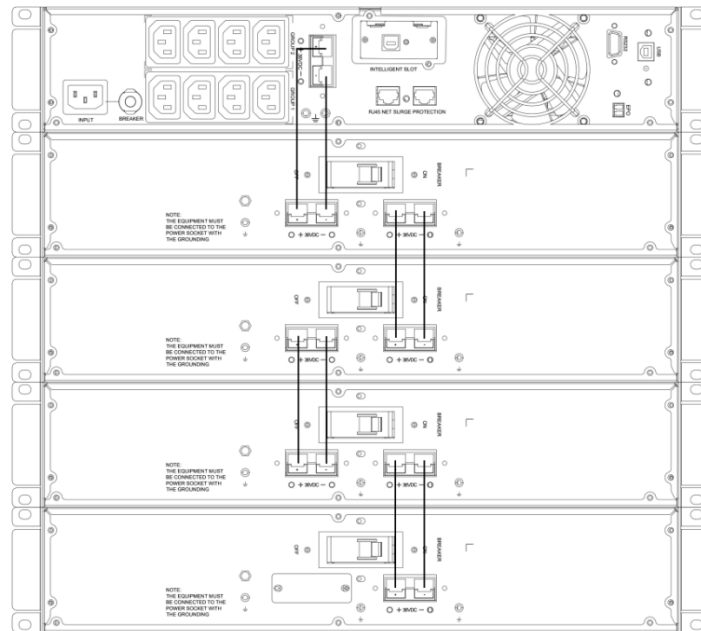

**Figure 57: Connect the EBP(s) - Example 4x EBP System**

## 10-20kVA 3-Phase UPS and Associated EBP (U10N32V, U10S32V, U15N32V, U15S32V, U20N32V, U20S32V, UVP480)

The 3-Phase systems may be configured as a Single System or as a Parallel System. In addition, the output may be connected to single-phase loads or to 3-Phase loads.

### Single Mode System Configuration with 3-Phase or Single-Phase Output

All UPS units by default are configured as a single mode system. A single mode system is a single UPS connected to an AC power source and that UPS provide the AC power to the load.

This section provides the electrical connections for Single UPS with a 3-Phase input and a 3-Phase or a Single-Phase Output.

- When selecting, connecting, and routing power cables, follow local safety regulations and rules.
- If external conditions such as cable layout or ambient temperatures change, verify in accordance with the IEC-60364-5-52 or local regulations.

1. Connect the UPS to the input source:

83. These UPS units will have input hardwire connections.
84. Ensure that there is no power on the input wires, use lock-out tag-out at the breaker panel. Refer to one of the tables below for the input breaker(s) and input power cable(s) to be used based on the configuration of the UPS unit being deployed. The breakers and cables must conform to the local wiring code according to environmental conditions (temperature and natural conditions). NOTE: Each part of the system must maintain a connected earth ground.
85. Remove the protective cover of the terminal block on the back of the UPS and retain the screws and cover.
86. Crimp the provided ring terminals onto each wire with a standard crimping tool, for the wire specified in the table below.
87. Connect each wire under the appropriate screw as indicated on the back of the UPS (see the appropriate diagram in Figure 58). NOTE: Each part of the system must maintain a connected earth ground.
88. If the rated voltage is 400 V, multiply the currents by 0.95. If the rated voltage is 415 V, multiply the currents by 0.92.
89. When the mains input and bypass input have the same input power source, configure both types of input power cables as mains input power cables. The cables listed in Table are used only when the following requirements are met:
90. Routing mode: Routing the cables over the cable ladder or bracket in a single layer (IEC60364-5-52 middle E).
91. The ambient temperature is 30°C.
92. The AC voltage loss is less than 3%, and the DC voltage loss is less than 1%.
93. 90°C copper flexible cable.
94. The length of the AC power cables are no longer than 30 m and DC power cables are no longer than 50 m.
95. After completing the wiring, confirm again that all wiring is correct.
96. Leave the terminal block cover off the rear panel for the next step of connecting the load(s).
97. Connect the load(s) to the UPS:
98. These UPS units have output hardwire connections.
99. Refer to one of the tables below for the output power cable to be used based on the configuration of the UPS unit being deployed. The cable must conform to the local wiring code according to environmental conditions (temperature and natural conditions). NOTE: Each part of the system must maintain a connected earth ground.
100. The protective cover on the terminal block should already be removed from the last step.
101. Crimp the provided ring terminals onto each wire with a standard crimping tool, for the wire specified in the table below.
102. Connect each wire under the appropriate screw as indicated on the back of the UPS (see the appropriate diagram in Figure 58). NOTE: Each part of the system must maintain a connected earth ground.
103. If the rated voltage is 400 V, multiply the currents by 0.95. If the rated voltage is 415 V, multiply the currents by 0.92.

- 104. If primary loads are non-linear loads, increase the cross-sectional areas of neutral wires 1.5–1.7 times.
- 105.
- 106. After completing the wiring, confirm again that all wiring is correct.
- 107. Leave the terminal block cover off the rear panel for the next step of connecting the EBP.

Recommended Cross-sectional Areas of Power Cables for Single Feed (same source is connected to the UPS Input and Bypass)

SKU	Wiring	Number of Phases	Voltage	Current Full Load*** (maximum)	External Input Circuit Breaker (typical)	Wire Size* (typical)
U10N32V	Input	3	380/400/415 VAC	26.9 A each phase	100 A**	25 mm <sup>2**</sup>
	Output	1	220/230/240 VAC	45.5 A	not required	16 mm <sup>2</sup>
	Input	3	380/400/415 VAC	26.9 A each phase	40 A each phase	10 mm <sup>2</sup>
	Output	3	380/400/415 VAC	15.2 A each phase	not required	6 mm <sup>2</sup>
U15N32V	Input	3	380/400/415 VAC	34.9 A each phase	100 A**	25 mm <sup>2**</sup>
	Output	1	220/230/240 VAC	68.2 A	not required	16 mm <sup>2</sup>
	Input	3	380/400/415 VAC	34.9 A each phase	40 A each phase	10 mm <sup>2</sup>
	Output	3	380/400/415 VAC	22.8 A each phase	not required	6 mm <sup>2</sup>
U20N32V	Input	3	380/400/415 VAC	42.9 A each phase	125 A**	35 mm <sup>2**</sup>
	Output	1	220/230/240 VAC	90.9 A	not required	25 mm <sup>2</sup>
	Input	3	380/400/415 VAC	42.9 A each phase	50 A each phase	16 mm <sup>2</sup>
	Output	3	380/400/415 VAC	30.4 A each phase	not required	10 mm <sup>2</sup>

Recommended Cross-sectional Areas of Power Cables for Dual Feed (one source is connected to the UPS Input and a different source is connect to the UPS Bypass)

SKU	Wiring	Number	Voltage	Current Full Load***	External Input Circuit	External Input Circuit	Wire Size Mains*	Wire Size Bypass*
-----	--------	--------	---------	----------------------	------------------------	------------------------	------------------	-------------------

		of Phase s		(maximum)	Breaker Mains (typical)	Breaker Bypass (typical)	(typical)	(typical)
<b>U10N32V</b>	Input	3	380/400/415 VAC	26.9 A each phase	40 A each phase	100 A **	10 mm <sup>2</sup>	25 mm <sup>2**</sup>
	Output	1	220/230/240 VAC	45.5 A	Not required	not required	16 mm <sup>2</sup>	16 mm <sup>2</sup>
	Input	3	380/400/415 VAC	26.9 A each phase	40 A each phase	40 A each phase	10 mm <sup>2</sup>	10 mm <sup>2</sup>
	Output	3	380/400/415 VAC	15.2 A each phase	Not required	not required	6 mm <sup>2</sup>	6 mm <sup>2</sup>
<b>U15N32V</b>	Input	3	380/400/415 VAC	34.9 A each phase	40 A each phase	100 A **	10 mm <sup>2</sup>	25 mm <sup>2**</sup>
	Output	1	220/230/240 VAC	68.2 A	Not required	not required	16 mm <sup>2</sup>	16 mm <sup>2</sup>
	Input	3	380/400/415 VAC	34.9 A each phase	40 A each phase	40 A each phase	10 mm <sup>2</sup>	10 mm <sup>2</sup>
	Output	3	380/400/415 VAC	22.8 A each phase	Not required	not required	6 mm <sup>2</sup>	6 mm <sup>2</sup>
<b>U20N32V</b>	Input	3	380/400/415 VAC	42.9 A each phase	50 A each phase	125 A **	16 mm <sup>2</sup>	35 mm <sup>2**</sup>
	Output	1	220/230/240 VAC	90.9 A	Not required	not required	25 mm <sup>2</sup>	25 mm <sup>2</sup>
	Input	3	380/400/415 VAC	42.9 A each phase	50 A each phase	50 A each phase	16 mm <sup>2</sup>	16 mm <sup>2</sup>
	Output	3	380/400/415 VAC	30.4 A each phase	Not required	not required	10 mm <sup>2</sup>	10 mm <sup>2</sup>

\*Terminal screw tightening torque: 4.5Nm (40 in-lbs).

\*\*Use cables and input circuit breakers specified in above table.

Note: Units configured for three phase input and single-phase output operation, the entire load connected to the UPS will transfer to L1 and Neutral of the 3-phase input when the UPS is operating in Bypass mode.

\*\*\*The current is specified at nominal input voltage.

108. Connect the EBP(s) to the UPS (see Figure 59):
109. As indicated in the mounting section, the EBP should be mounted under or near the UPS.
110. Use the battery cable included with the UPS. This cable has ring terminals on one end and a battery cable connector on the other end.
111. Connect each wire under the appropriate screw as indicated on the back of the UPS (see the appropriate diagram in Figure 58). NOTE: Each part of the system must maintain a connected earth ground.
112. After completing the wiring, confirm again that all wiring is correct.
113. Close the terminal block cover on the rear panel of the UPS and secure it with the screws retained from an earlier step.
114. Plug the other end of this cable into the back of the EBP. Insert and press the connector tightly together to ensure a proper connection.
115. For additional EBP units in the system connect with the battery cable provided with the EBP. This cable has a battery cable connector on both ends.
116. Verify that the EBP connections are tight, and that adequate bend radius and strain relief exist for each cable. This system may have up to 8 EBP units connected.

**Wiring for 3:1 single feed**

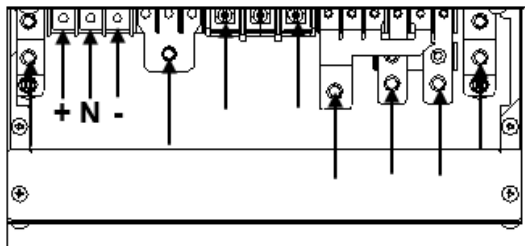

**Wiring for 3:1 dual feed**

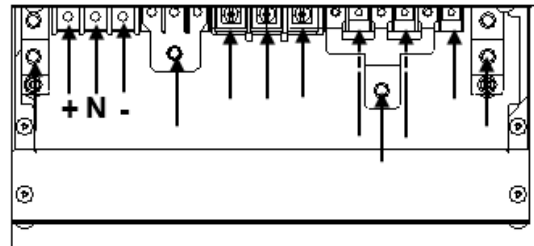

**Wiring for 3:3 single feed**

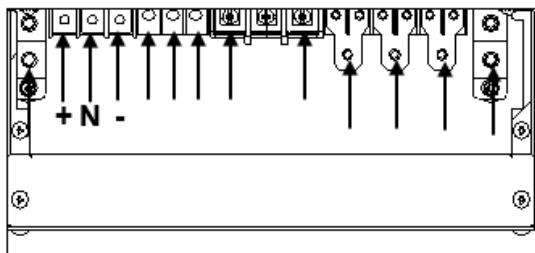

**Wiring for 3:3 dual feed**

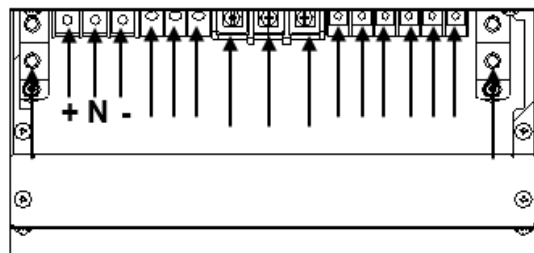

Earth	BATTERY			OUTPUT				INPUT						Earth		
GRD	+	N	-	L1	L2	L3	N	Bps-N	Mains-N	Bps-L1	Mains-L1	Bps-L2	Mains-L2	Bps-L3	Main-L3	GRD

**Figure 58: Wire Connections for Different UPS Configurations**



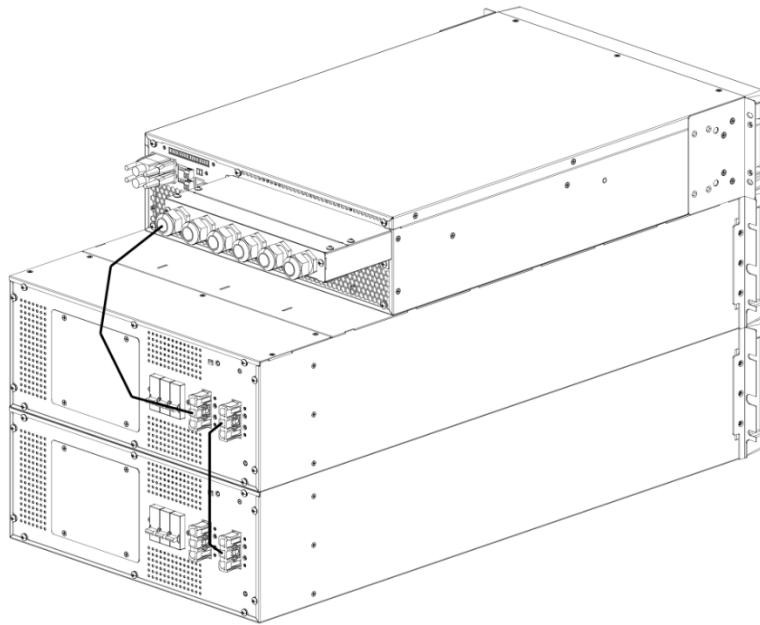
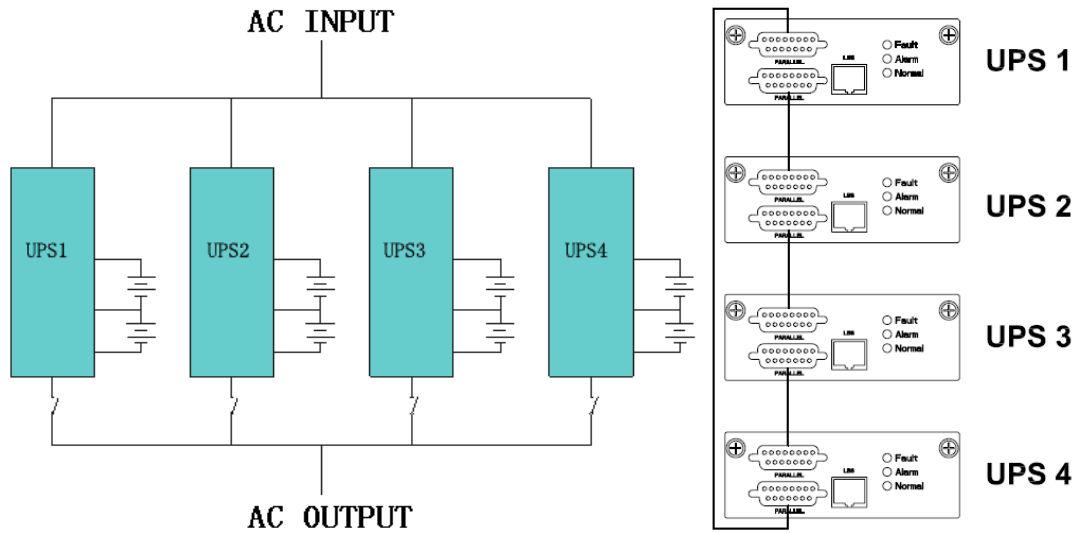

**Figure 59: Example of a System with 2 EBP Units Connected**

### **Parallel Mode System Configuration with 3-Phase or Single-Phase Output**

This section provides the electrical connections for two or more UPS units in a Parallel System with a 3-Phase input and a 3-Phase or a Single-Phase Output.

All 3-phase UPS units may optionally be configured into a parallel mode system. Figure 60 shows a high-level power and control connection diagrams of the parallel UPS system. A parallel mode system allows two to four UPS unit of the same SKU to be connected in parallel. NOTE: Initial release of the product only allows two UPS units to be connected in parallel. The parallel mode allows the group of UPS units to behave as one large UPS system. NOTE: There are critical restrictions for connecting these units in parallel.



**Figure 60: Parallel System Power/Control Connections**

To ensure that all UPS units in the system are equally utilized and comply with relevant wiring rules, follow the requirements below:

- All UPS units in the system must have same SKU.
- The input of all the UPS units must be connected to a common input bus.
- All UPS units in the system must be connected to the same bypass source.
- All UPS units in the system must be connected to a common output bus.
- The length and specification of all UPS power cables (main input, bypass input and the output cables) should be the same type and same length. This helps to facilitate load sharing between the UPS units when operating in all working modes.
- The UPS units should be physically located near each other to minimize the load sharing effects due to environmental conditions.

**Parallel Mode Wiring**

Following the power and control wiring as indicated in Figure 60.

1. Connect the UPS Parallel System to the input source:
  117. Before wiring together, make sure each UPS input breaker is in the “off” position and there is no output from each UPS unit.
  118. Connect the Mains inputs of all UPS units in the parallel system to a common source with the same cable type and cable length (see Figure 58).
  119. If single source, connect the bypass inputs of all UPS units in the parallel system to the same common source as the Mains inputs with the same cable type and cable length (see Figure 58).
  120. If dual source, connect the bypass inputs of all UPS units in the parallel system to a common source with the same cable type and cable length (see Figure 58).
1. Connect the UPS Parallel System to the common output bus:

121. Connect the outputs of all UPS units in the parallel system to a common output bus with the same cable type and cable length (see Figures 58 and 60).
122. Outputs of all units in the parallel system must be connected the same; as single-phase, or as three-phase.
123. Connect the EBP(s) to the UPS (see Figure 59):
124. As indicated in the mounting section, the EBP should be mounted under or near the UPS.
125. Use the battery cable included with the UPS. This cable has ring terminals on one end and a battery cable connector on the other end.
126. Connect each wire under the appropriate screw as indicated on the back of the UPS (see the appropriate diagram in Figure 58). NOTE: Each part of the system must maintain a connected earth ground.
127. Connect the Parallel System Control (see Figure 60):
128. Connect the shielded and double insulated control cables (one provided with each 3-Phase UPS unit) in a ring configuration between UPS units as shown in Figure 60. The ring configuration ensures high reliability of the control.

#### Parallel Mode Setup and Startup

Each UPS unit in the Parallel mode system must be properly configured before the Parallel mode system is powered up.

129. Confirm that all breakers in the Parallel Mode system are open.
130. Confirm that the Input/Output power connections and the input phase sequence is correctly connected.
131. Confirm that the +/- battery voltage of all EBP groups are correct.
132. Confirm that the parallel control cables are connected in a ring configuration between all UPS units in the Parallel mode system (control connection in Figure 60).
133. Power ON the first UPS unit and set the working mode to Parallel, set the Parallel ID to 1, set the number of parallel UPS units to the number that will be in the system (2-4), set the ID of the redundant UPS unit, if redundancy is desired in the system (0-3, no redundancy = 0). Require setting the in series number, capacity of battery. The output voltage level and Bypass protection range are default setting.
134. Power OFF the first UPS unit, make sure the UPS is OFF. Power on the second UPS unit and follow the configurations steps above for the second UPS unit. This unit should have all the same settings except the Parallel ID on this UPS unit should be 2.
135. Make these configuration settings for the rest of the UPS units in the Parallel mode system; making sure the Parallel ID is unique for each UPS unit.
136. After all UPS units in the Parallel mode system are configured, power ON the UPS units in ECO mode and confirm that all settings are correct. Each UPS unit should have a unique Parallel ID.
137. Then turn ON all battery breakers and confirm the parameter (V/I) are normal.
138. Set all units in the Parallel mode system to normal mode.
139. Then connect the load(s) and confirm the output current from the system is balanced.

- 
140. Toggle the utility breaker ON and OFF to test all the UPS converter systems from the utility to battery and restore function are properly working.
141. If all is properly working, then the system may be powered up.

### **Optional MBS for 3-Phase UPS**

## Section 5 – Replacing Battery Cartridges

### Internal Battery Cartridges in the 1-3kVA UPS Units (UVC024, UVC036, UVC048, UVC072)

Replace battery cartridges with only the same SKU. It is recommended to replace all battery cartridges in a system at the same time with new battery cartridges of the same SKU for that unit (UPS and EBP).

1. Change to Bypass Mode, this will not allow the UPS to transition to Battery Mode while the battery cartridges are being replaced.
2. Remove the faceplate:
  142. Press both sides of UPS faceplate until the latches release (see Figure 61).

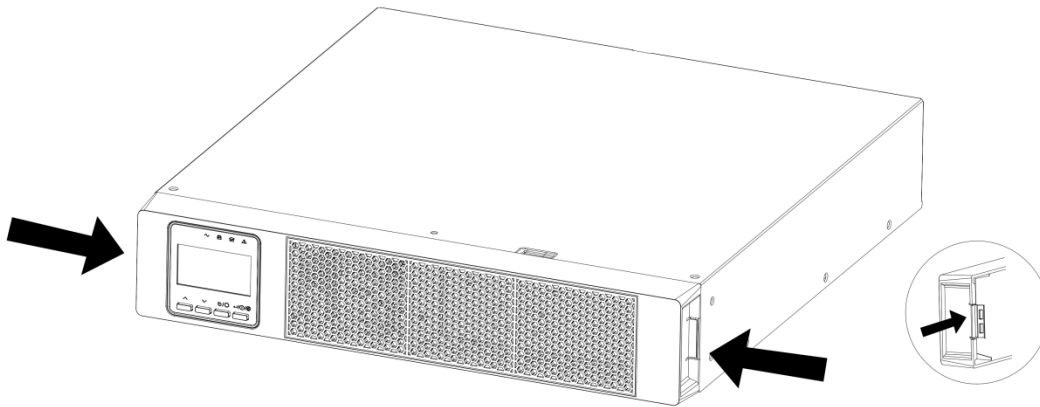

**Figure 61: Press the Latches to Remove Faceplate**

143. Remove the faceplate (see Figure 62).

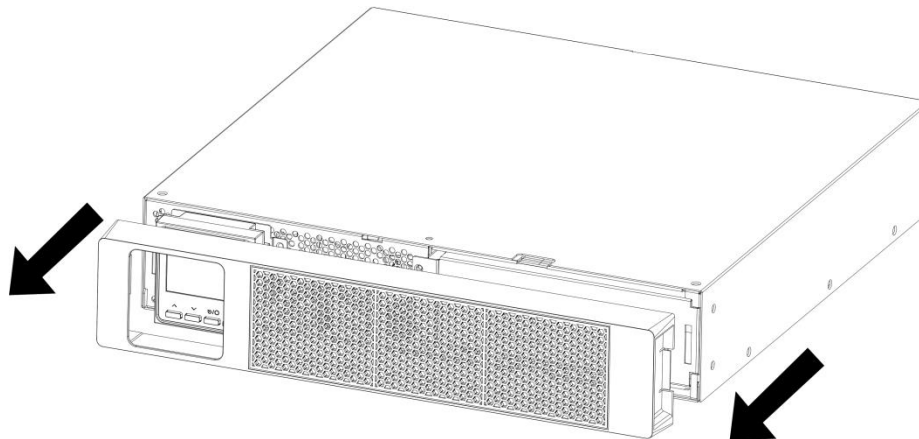

**Figure 62: Remove the Faceplate**

144. Disconnect the internal battery cartridge:
145. Disconnect the internal battery cartridge connector (see Figure 63). Press the connector tightly together to ensure a proper connection.

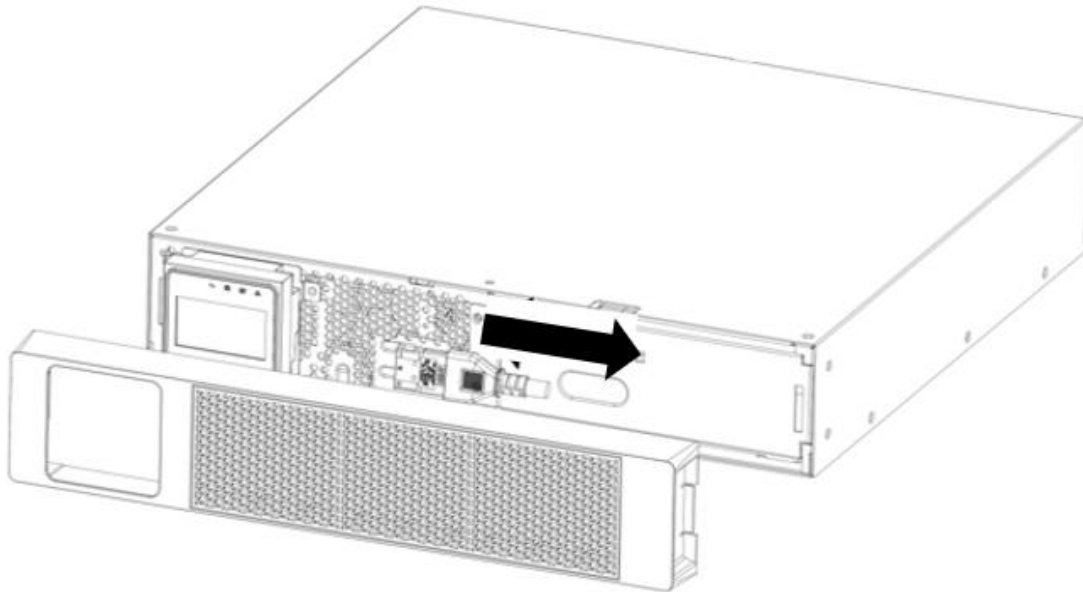

**Figure 63: Disconnect the Internal Battery Cartridge Connector**

146. Loosen the outer screws on the battery covers, move the battery cover to the center, then pull the outside out (see Figure 64).

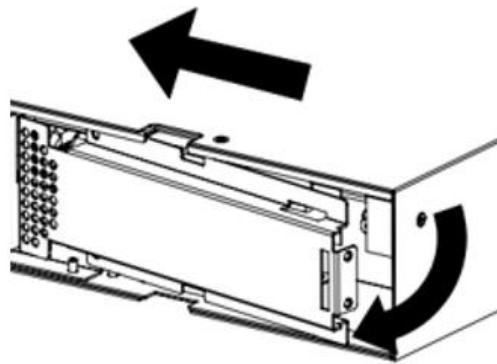

**Figure 64: Remove Battery Cover**

147. Slide the battery cartridge out of the UPS.
148. Slide the new battery cartridge into the UPS.
149. Replace the battery cover (reverse order of above steps 4 - 1).
150. Connect the new battery cartridge to the UPS. Press each connector tightly

together to ensure a proper connection.

- 151. Replace the UPS faceplate.
- 152. Change to Normal Mode.

## EBP Battery Cartridge Sets for the 1-3kVA UPS Systems (UVD024, UVD036, UVD048, UVD072)

Replace battery cartridges with only the same SKU. It is recommended to replace all battery cartridges in a system at the same time with new battery cartridges of the same SKU for that unit (UPS and EBP).

- 1. Change to Bypass Mode, this will not allow the UPS to transition to Battery Mode will the battery cartridges are being replaced.
- 2. Remove the faceplate:
  - 153. Press both sides of EBP faceplate until the latches release and remove (see Figure 65).

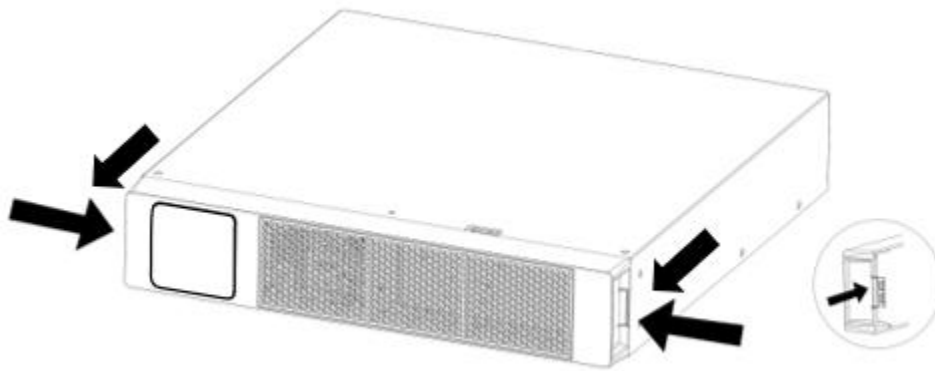

**Figure 65: Press the Latches and Remove Faceplate**

- 154. Loosen the outer screws on both battery covers, move the battery covers to the center, then pull the outside out (see Figure 66).

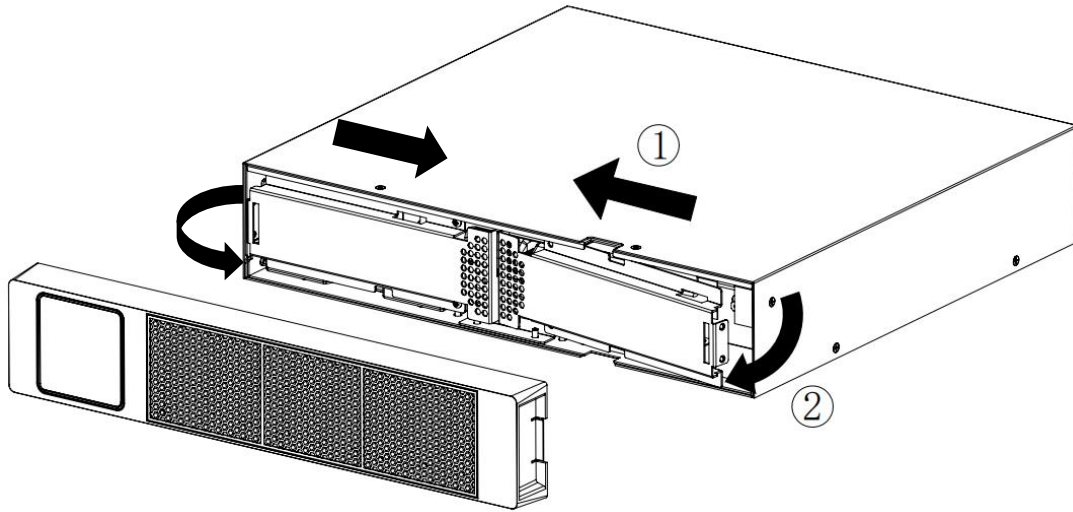

**Figure 66: Remove the Faceplate**

155. Disconnect the internal battery cartridges:
156. Pull both battery cartridge connectors through the middle hole in the chassis, disconnect a battery cartridge from each connector (see Figure 67). Press the connector tightly together to ensure a proper connection. Connect the other battery cartridge in the EBP. Both internal battery cartridges should be connected. Press each connector tightly together to ensure a proper connection.

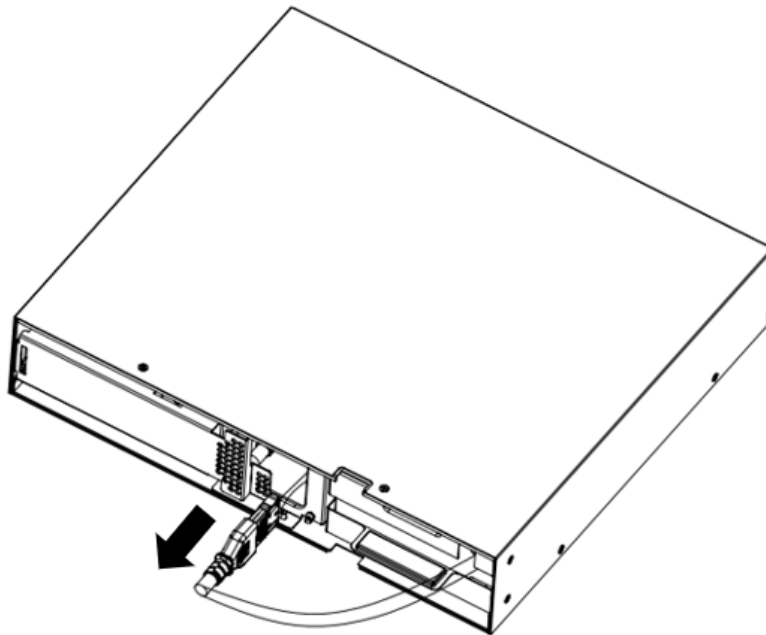

**Figure 67: Disconnect the First Internal Battery Cartridge Connector**



- 157. Slide both battery cartridges out of the UPS.
- 158. Slide the new battery cartridges into the UPS.
- 159. Replace the battery covers (reverse order of above steps 4 - 1).
- 160. Connect the new battery cartridges to the EBP. Press each connector tightly together to ensure a proper connection.
- 161. Replace the UPS faceplate.
- 162. Change to Normal Mode.

## EBP Battery Cartridge Sets for the 5-10kVA UPS Systems (UVD240)

Replace battery cartridges with only the same SKU. It is recommended to replace all battery cartridges in a system at the same time with new battery cartridges of the same SKU for that unit (UPS and EBP).

- 1. Change to Bypass Mode, this will not allow the UPS to transition to Battery Mode will the battery cartridges are being replaced.
- 163. Remove the faceplate:
- 164. Press both sides of EBP faceplate until the latches release (see Figure 68). Then remove the faceplate form the front of the unit.

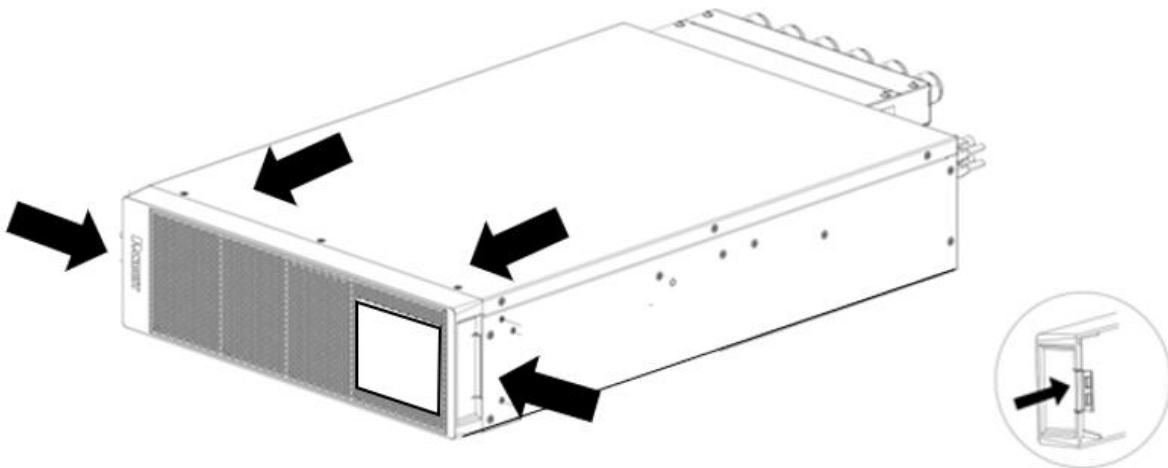

**Figure 68: Press the Latches to Remove Faceplate**

- 165. Disconnect all three battery cartridge connectors (see Figure 69).

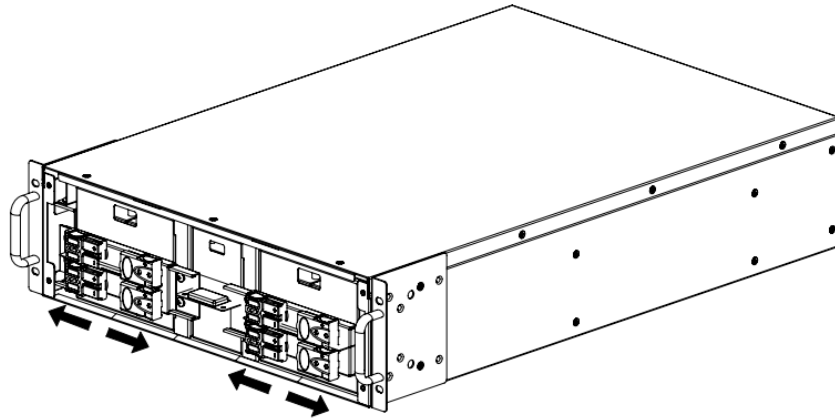

**Figure 69: Disconnect Internal Battery Cartridges**

166. Remove the battery baffle screws and baffles and retain (see Figure 70).

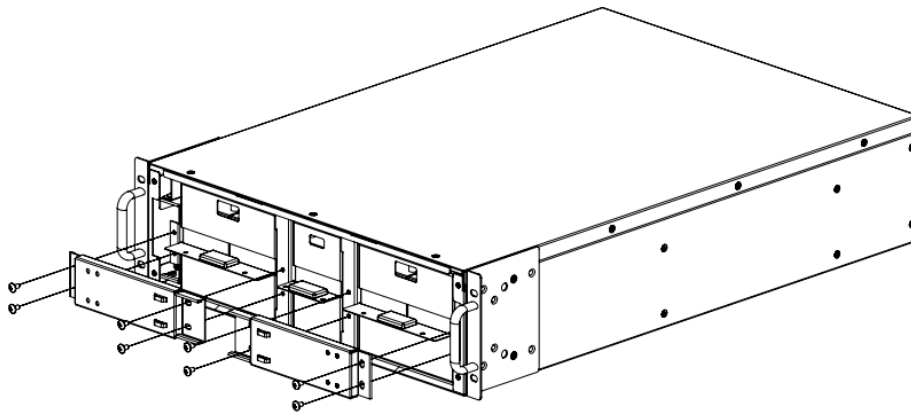

**Figure 70: Remove the Battery Baffles**

167. Refer to the handling instruction, take out all three battery cartridges (see Figure 71). Two larger battery cartridges and one smaller battery cartridge.

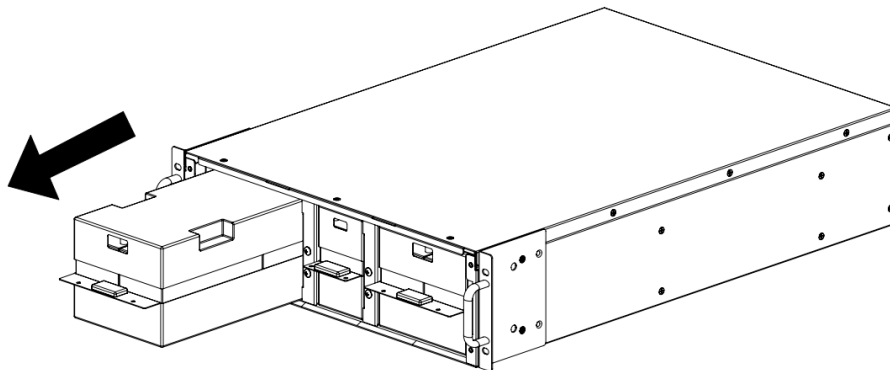

**Figure 71: Remove Battery Cartridges from EBP**

168. Refer to the handling instruction, slide the new battery cartridges into the EBP unit.
169. Reinstall the battery baffles the screws (reverse order of above steps 4 - 1).
170. Connect the new battery cartridges to the EBP. Press each connector tightly together to ensure a proper connection.
171. Replace the UPS faceplate.
172. Change to Normal Mode.

### **EBP Battery Cartridge Sets for the 10-20kVA 3-Phase UPS Systems (UVD480)**

Replace battery cartridges with only the same SKU. It is recommended to replace all battery cartridges in a system at the same time with new battery cartridges of the same SKU for that unit (UPS and EBP).

1. Change to Bypass Mode, this will not allow the UPS to transition to Battery Mode will the battery cartridges are being replaced.
2. Remove the faceplate:
  - i. Press both sides of EBP faceplate until the latches release (see Figure 72). Then remove the faceplate form the front of the unit.

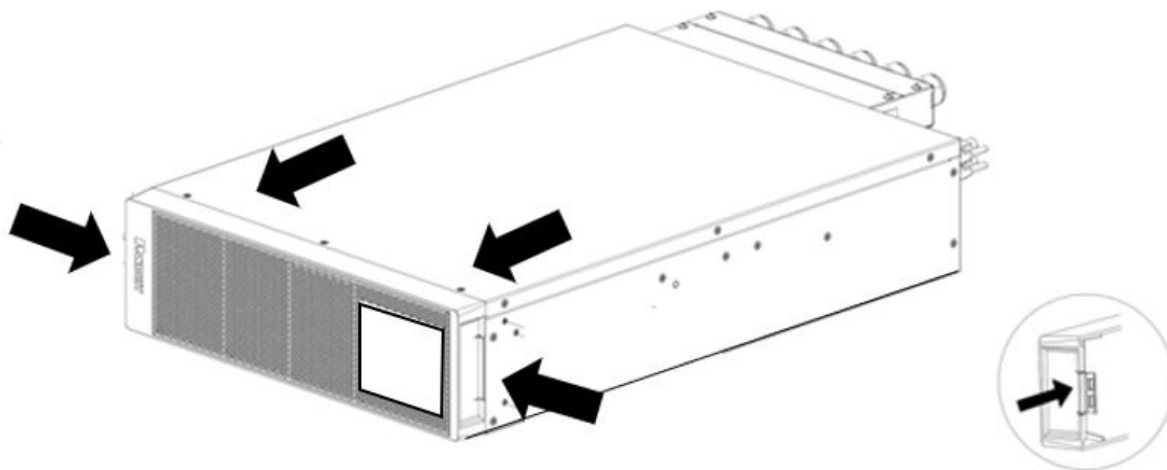

**Figure 72: Press the Latches to Remove Faceplate**

3. Remove the screws and battery baffle from EBP (see Figure 73).

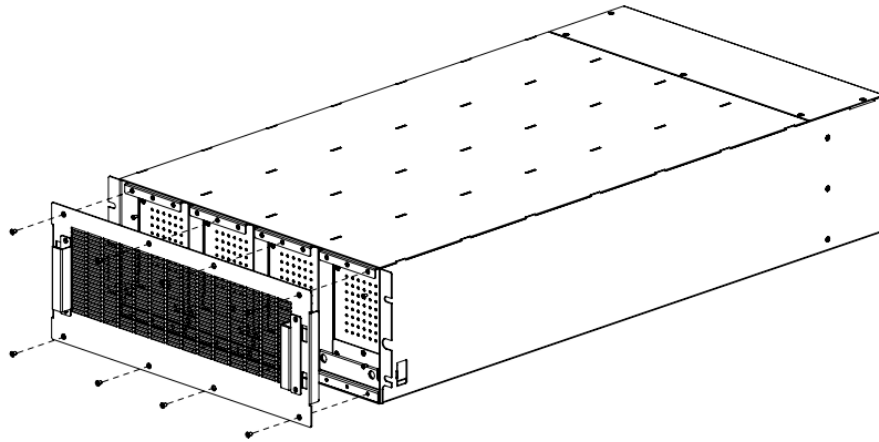

**Figure 73: Remove Battery Baffle on the EBP**

4. Refer to the handling instruction, remove all battery cartridges (see Figure 74).

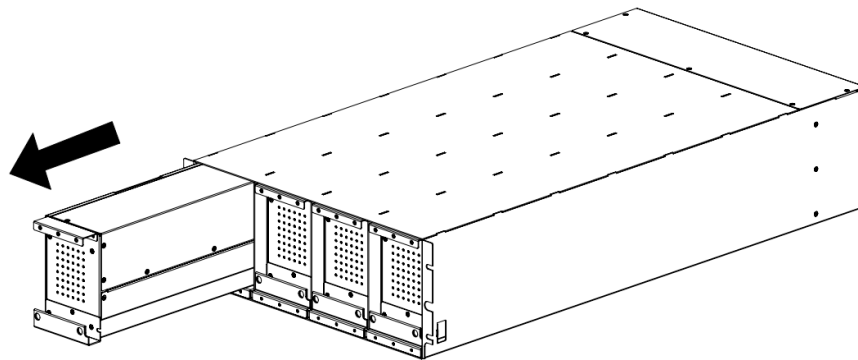

**Figure 74: Remove Battery Cartridges from EBP**

173. Refer to the handling instruction, slide the new battery cartridges into the EBP unit.
174. Reinstall the battery baffles the screws (reverse order of above steps 4 - 1).
175. Connect the new battery cartridges to the EBP. Press each connector tightly together to ensure a proper connection.
176. Replace the UPS faceplate.
177. Change to Normal Mode.

---

**Appendix A: What's Included: 1-3kVA NA UPS  
(U01N11V, U01S11V, U01N13V, U01S13V,  
U02N11V, U02S11V, U03N11V, U03S11V,)**

## **Appendix B: What's Included: 1-3kVA EU UPS (U01N12V, U01S12V, U02N12V, U02S12V, U03N12V, U03S12V)**

1. Tower Mount Kit (with 4 pieces)
2. Rack Mounting Brackets (2 pieces)
3. Safety Warning Sheet (1 Sheet)
4. Selection Guide (1 Booklet)
5. DB9 to DB9 RS232 1,5M Serial Cable (1 piece)
6. USB-1 to USB-B 1.2M Serial Cable (1 piece)
7. Internal Battery Cartridge Installed [UVC036, UVC048 or UVC072 depending on UPS SKU] (1 cartridge)
8. Schuko CEE7/EU1-16P to C14 or C20 Input Power Cord depending on UPS SKU (1 piece)
9. BS1363A to C14 Input Power Cord (1 piece)
10. Rack Rail Mounting Kit [URMKIT1] (1 kit) – N versions only
11. Intelligent Network Card Installed [UNC001] – N version only

---

## **Appendix C: What's Included: 1-3kVA EBP (UVP024, UVP036, UVP048, UVP072)**

---

**Appendix D: What's Included: 5-10kVA UPS  
(U05N11V, U05S11V, U06N11V, U06S11V,  
U06N12V, U06S12V, U10N11V, U10S11V,  
U10N12V, U10S12V)**



---

## **Appendix E: What's Included: 10-20kVA UPS (U10N32V, U10S32V, U15N32V, U15S32V, U20N32V, U20S32V)**

---

## **Appendix F: What's Included: 5-10kVA EBP (UVP240)**

---

## **Appendix G: What's Included: 10-20kVA EBP (UVP480)**

---

## Appendix H: What's Included: Maintenance Bypass Switch (UMB20K)



Sales, Marketing, Technical and Channel representative of Panduit in Middle East & Africa.  
info@itrident.com  
[www.itrident.com](http://www.itrident.com)